

# STRIXO2K

**Indoor/outdoor wireless DT detector  
with vertical curtain coverage for NG-  
TRX intrusion detection systems**



Addressee for this information:  User |  Installer

## 1 DESCRIPTION

STRIXO2K is a NG-TRX wireless dual technology detector. Curtain coverage is ideal to protect windows, doors, gates and walls.

The device supports the connection of a magnetic and/or roll-up shutter contact to realize a three-level perimeter protection.

The detector includes two sections working in AND mode.

**Infrared section (IR):** digital PIR sensor with temperature compensation and environment monitoring, vertical curtain lens with white light protection.

**Microwave section (MW):** 24GHz DRO planar antenna.

Moreover, the detector features anti-blinding function.

STRIXO2K can be programmed using BrowserOne software.

Optional accessories available:

- **ANGSGX**, bracket for corner mount
- **CUPSGX**, sunshield for outdoor installations
- **SNDSGX**, joint for corner mount

STRIXO2K is compatible with Villeggio NG-TRX, Pregio and Proxima series control units. Connection to Pregio and Proxima control units requires use of GATEWAY2K.

Control unit	STRIXO2K
PREGIO series	2.3.2.0 or higher
VILLEGGIO NG-TRX series	8.3.3.0 or higher
PROXIMA series	1.0.2 or above

STRIXO2K is certified IMQ - Security Systems.

## 2 PCB

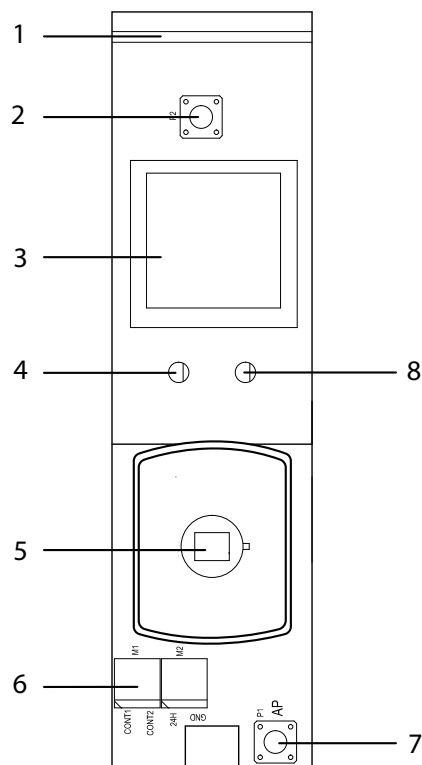

- 1 RF antenna
- 2 Learning button P2
- 3 MW antenna
- 4 MW LED (blue)
- 5 PIR sensor
- 6 Terminal board
- 7 Tamper button
- 8 IR LED (green)

### 3 TECHNICAL DATA



Model		STRIXO2K	
<b>Identification</b>			
Technology	IR + MW		
Coverage type	vertical curtain		
<b>IR section</b>			
PIR sensors number	1		
Max range	8	m	
Pulse count	5		
Pre-alarm time	5		
Opening	7°	°	
No. of IR sensitive zones	2 beams		
<b>MW section</b>			
MW max range	8	m	
Pulse count	5		
Pre-alarm time	5		
Standard TX frequency	24,000	GHz	
MW horizontal coverage	80°	°	
MW vertical coverage	35°	°	
<b>General features</b>			
<b>Operating voltage</b>	Power supply	7,2 (DC)	V
	Minimum power supply	3,5	V
	Compatible battery	2ER14505 7V2 2.7 Ah	
	Discharged battery threshold	4,9	V
	Battery restore threshold	5,6	V
<b>Current consumption at 7.2 V</b>	Power on in progress	1,8	mA
	Inactive mode	21,0	µA
	Consumption for transmission at minimum power	23	mA

Model		STRIXO2K	
<b>General features</b>			
<b>Operating times</b>	Power-on stand-by	25	s
	Walk test	8	min
	Post-alarm inhibition time	In walk test mode: 5 s; in system test mode: 5 s; in operating mode with system armed: 5 s; in operating mode with system disarmed: 5 min (1)	
	Supervision	240 (2)	min
<b>Radio connection range</b>	nominal	850 (3)	m
	maximum	1500 (3)	m
<b>Max power in transmission mode</b>		25	mW
<b>Transmission frequencies</b>		868.120 MHz; 868.820 MHz; 869.525 MHz	MHz
<b>Autonomy</b>		2,5 (4)	years
<b>Working temperature</b>		-25 / +55	°C
<b>Protection class</b>		IP55 (5)	
<b>IMQ certified</b>		EN50131-2-4: grade 2; EN50131-5-3 (6)	
<b>Environmental class</b>		3	
<b>Dimensions and weight</b>		L39 × H155 × P44, 140 g	
<b>Parts supplied</b>		Screws, dowels, rubber washers, cable conduit, front screws washers, battery	

- (1) in operating mode with system armed, inhibition time is 5 seconds for the first 3 alarms, for the following alarms it will be 5 minutes
- (2) adjustable via BrowserOne
- (3) refer to the reception of 99% of transmitted packets, with devices installed in open field at 1,5m height, without antennas (nominal range) / with antennas (max range) oriented in the most favourable direction respectively
- (4) calculated with device set to default settings and 20 minute supervision time. Settings that cause duration variation: inhibition 30s = -60%; disabled LED = +5%; anti-blind active = -5%
- (5) use of supplied washers required
- (6) to comply with EN50131-5-3 grade 1, set supervision time equal to or below 60 minutes; to comply with EN50131-5-3 grade 2, set supervisiione time equal to or below 20 minutes

## 4 PRECAUTIONS BEFORE DEVICE MOUNTING



The table of contents and general warnings are at the end of this manual.

Before installing the product, please read the following indications carefully.

### 4.1 General considerations

- Make sure the device operating field is free and devoid of zones darkened by obstacles.
- Adjust microwave range so that it does not extend beyond glazing or plastic curtains.
- Do not install the device near swaying or vibrating metal objects (ex. fridge/refrigerators groups, window blinds, metal roller shutters).
- Avoid installation near heat sources or drafts.
- Do not touch PIR sensor silicon filter.
- In case of detector installation in places with high frequency of people passage with disarmed system, set inhibition time to 5 minutes to limit the number of transmissions and prevent premature battery depletion.
- For a better reception we recommend installing intrusion detection control units in the central area of the building to protect and over the ground level.

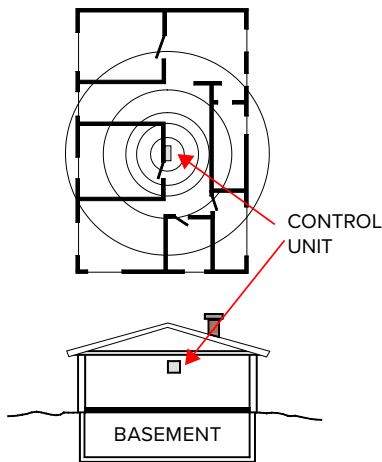

### 4.2 Outdoor installation positions

#### Possible installation

- Perimeter installation with non-overlapping coverage areas.

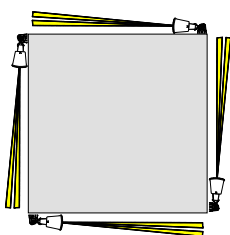

- Installation of detectors on one side, in opposed positions

at a distance of more than 15 metres.

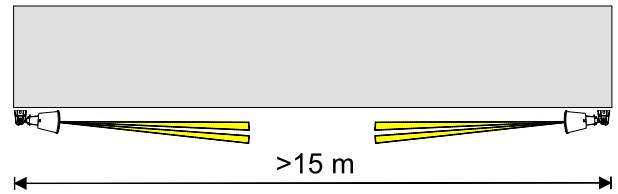

- Outdoor installation, protected by a porch or a balcony.

### Wrong installation positions

- Installation of detectors on one side, in opposed positions at a distance of less than 15 metres.

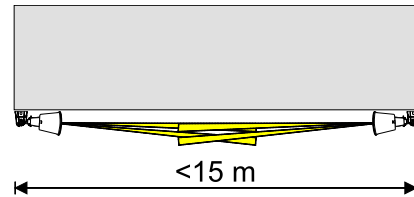

- Detector orientation towards areas with vehicles passage at less than 8 metres distance.
- Detector orientation towards trees/bushes at less than 8 metres distance.
- Detector direct orientation towards the sun.
- Pole mount (with/out sunshield): bad weather may cause false alarms.
- In environments with pets/animals.

### 4.3 Environment limits

The use of some building materials may reduce the detector wireless signal strength.

Example:

- plywood and honeycomb walls: 90-100% of full strength;
- solid / hollow brick walls 65-95% of full strength;
- concrete walls or metal sheet and plaster: 0-70% of full strength.

Metal grids, metal gates, and glasses may also affect (i.e. diminish) detector strength.

### 4.4 Protection from electrostatic discharges

The electronic board of the detector may be damaged by electrostatic discharges.

The installer must completely avoid any presence of electrostatic discharges both during installation and maintenance.

### 4.5 Definition of installation position

The detector can be installed:

- in **HORIZONTAL** position (ceiling-mount, recommended for doors and windows): install the detector at the centre of the door/window.
- in **VERTICAL** position (recommended for gates and walls protection): with lens looking down and detector body on the top corner. In case of gates, install the detector on a

sloping joint.

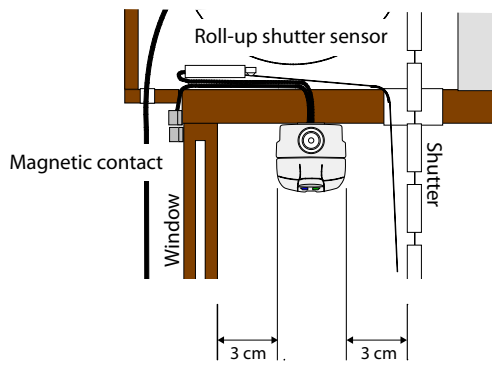

When installing the detector in horizontal position, place it at the centre of the space between window/door and its shutter/roll-up shutter.

Leave at least 3 cm at each side.

### Window protection

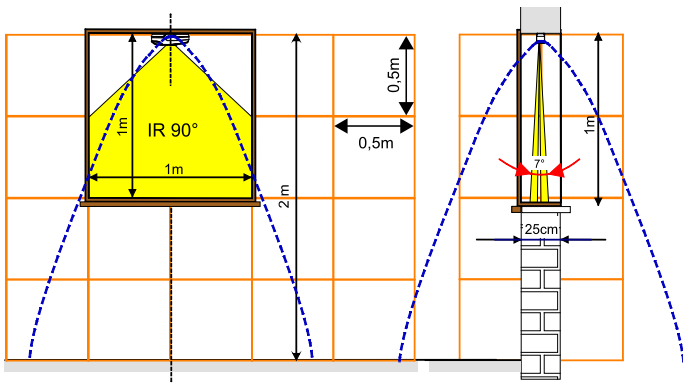

Range recommended: 2 m (25%).

### Door protection

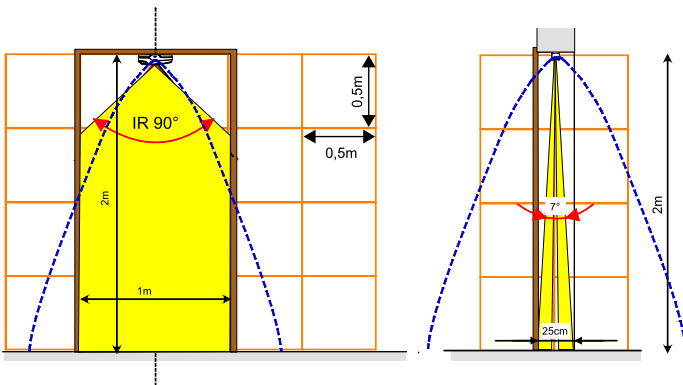

Range recommended: 4 m (50%).

### Gate protection

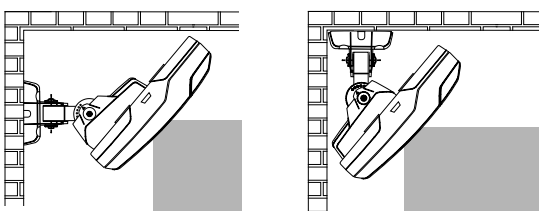

Mount the detector on a 45° sloping joint. Two are the

mountings allowed: see above diagram.

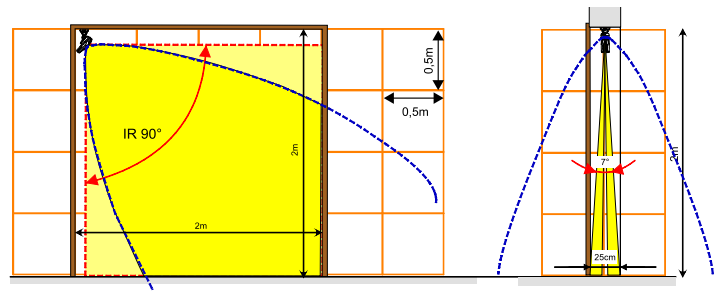

Range recommended: 6 m (75%).

### Wall protection

The detector can be used to protect walls, with or without joints usage. When used to protect an outside wall, install also CUPSGX optional sunshield.

### with optional joint

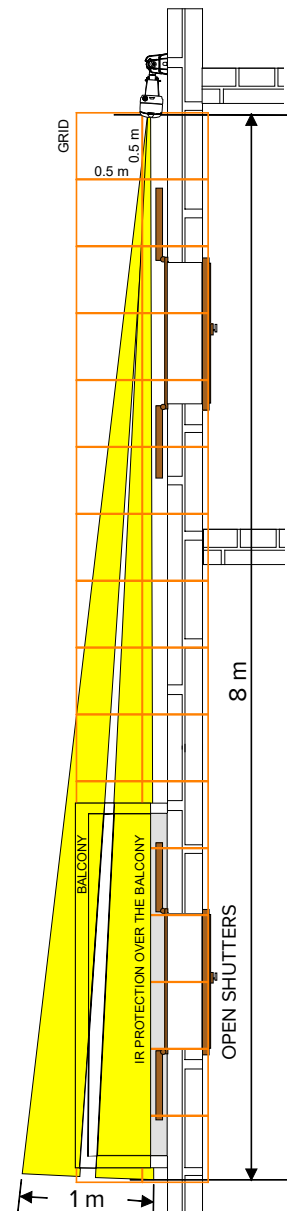

Install the detector at 1.5 m from ground level.

Tilt the joint of 3.5° towards the outside: align the triangle to

the reference sign indicated in the picture.

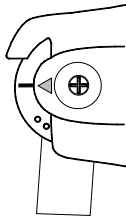

without optional joint

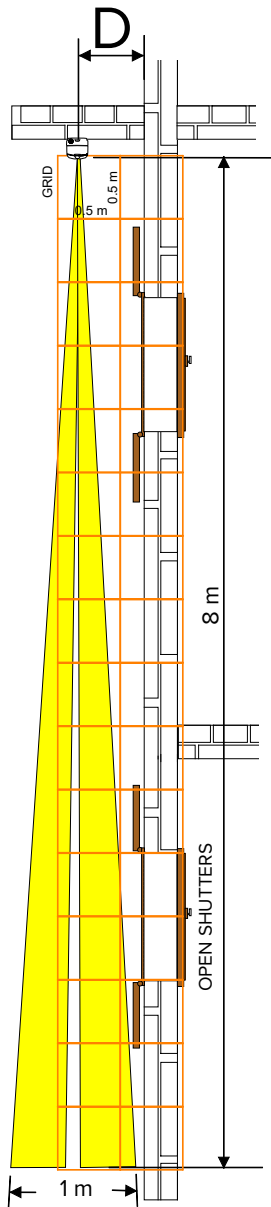

Install the detector at 1.5 m from ground level. Choose the minimum distance (D) of the detector from the wall according to the range to set:

Range to set	Minimum distance from wall (D)
2 m	18 cm
4 m	35 cm
8 m	70 cm

## 5 DEVICE MOUNTING



### • Opening the housing

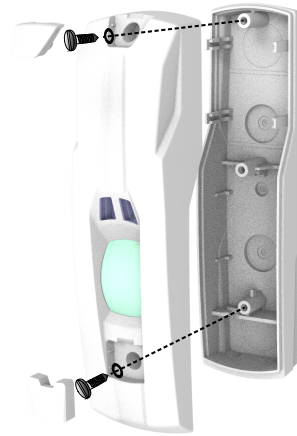

- remove caps covering front screws
- unscrew fixing screws

**!** To ensure IP class protection insert washers between screws and cover holes.

- separate the cover from the base

### • Removing the electronic board

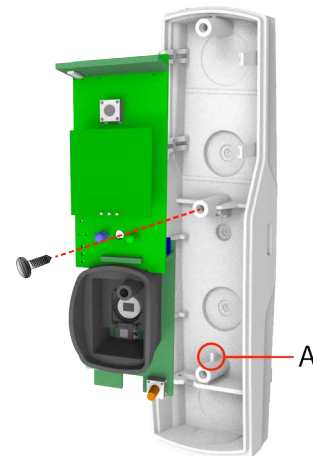

- unscrew the fixing screw
- remove the board from the lower hook (A)

### • Base wall mount

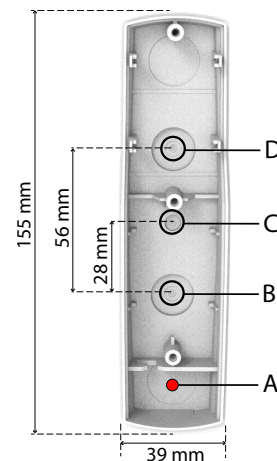

- open predrilled holes for the passage of magnetic contacts and roll-up shutter sensor wires (A)
- open predrilled areas B, D
- if required, install the kit for protection against removal from the surface at this step (see paragraph 5.1 p. 7)
- fix the detector base to the wall using screws and dowels

 *insert also washers supplied*

• **Base corner mount**

ANGSGX optional bracket required.

- if required, install the kit for protection against removal from the surface at this step (see paragraph 5.1 p. 7)

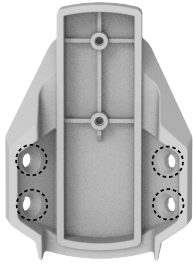

- fix the bracket to the wall

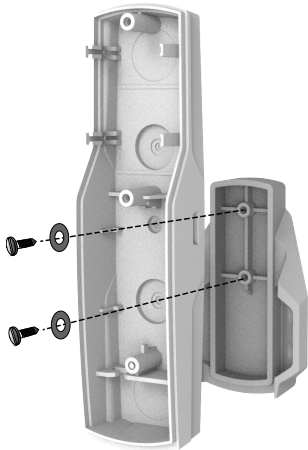

- open predrilled holes for the passage of magnetic contacts and roll-up shutter sensor wires (A)
- open predrilled areas B, C
- fix the detector base to the bracket using screws and dowels

 *insert also washers supplied*

See the relevant instructions.

• **Mounting on optional joints**

SNDSGX optional joint required. For information on how to assemble the joint see relevant instructions.

- if required, install the kit for protection against removal from the surface at this step (see paragraph 5.1 p. 7)

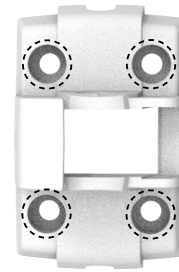

- fix the joint base to the wall

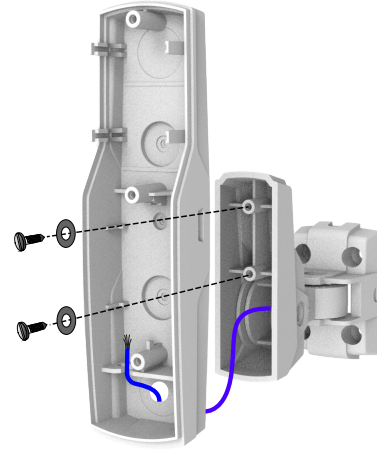

- open predrilled holes for the passage of magnetic contacts and roll-up shutter sensor wires (A)
- open predrilled areas B, C
- fix the detector base to the joint body using screws and dowels

 *insert also washers supplied*

• **Battery wiring**

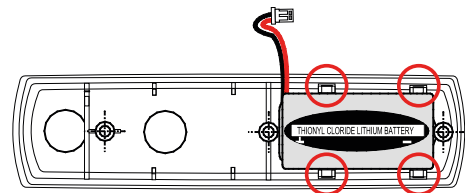

- fit the battery among the four clips

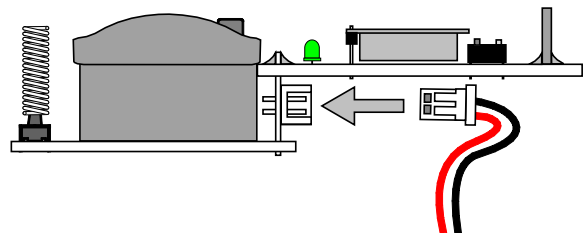

- wire the battery cable connector to the corresponding one on the board

• **Board positioning**

Disconnect the battery following the steps above in reverse order:

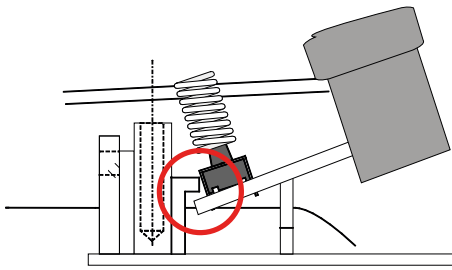

- position the electronic board under the lower hook
- tighten the fixing screw

• **Wirings**

- insert the cable into the hole drilled; insert also the cable conduit supplied

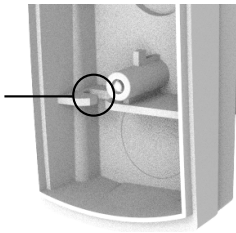

- place the cable on the area indicated on the diagram

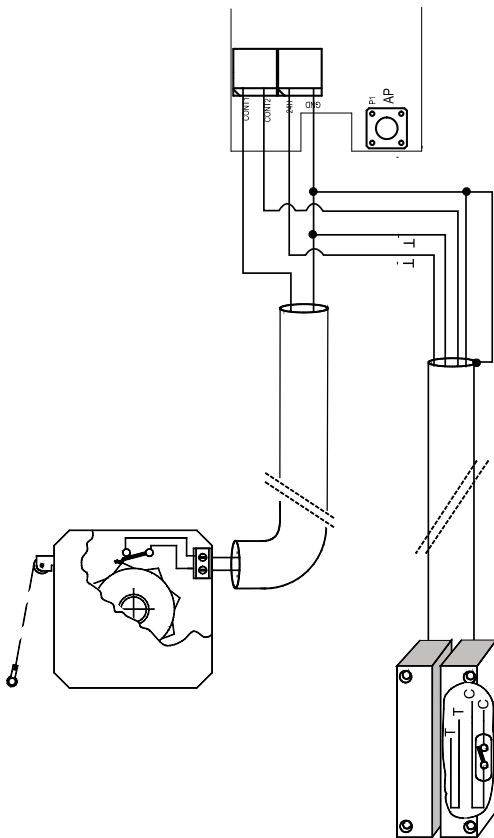

- wire terminals
- It is possible to connect simultaneously: two magnetic contacts, two roll-up shutter sensors, or one magnetic contacts and one roll-up shutter sensor.

⚠ *Max lengths: roll-up shutter cable: 1 m; magnetic contact cable: 20 m*

• **Device setup**

For detector configuration see the following sections.

• **Closing the housing**

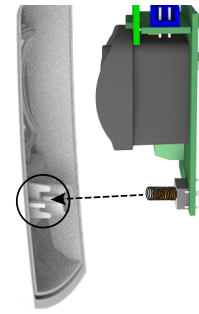

- position the cover on the base

⚠ *make sure the tamper protection spring fits correctly to its place.*

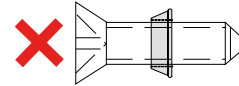
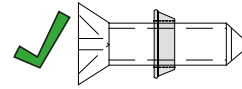

⚠ *to ensure IP class protection insert washers on front screws as indicated in the above diagram.*

- fasten cover fixing screws
- place caps covering front screws

**5.1 Protection against removal from the mounting surface**

Compliance with EN 50131 regulation grade 2 requires that the device is protected against removal from the mounting surface.

Install the proper kit for protection against removal **before** fixing the detector base, the ANGSGX bracket or the SNDS-GX joint to the wall.

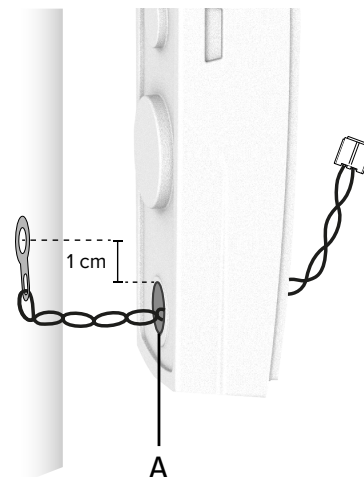

KSAS1013 kit (GREEN)

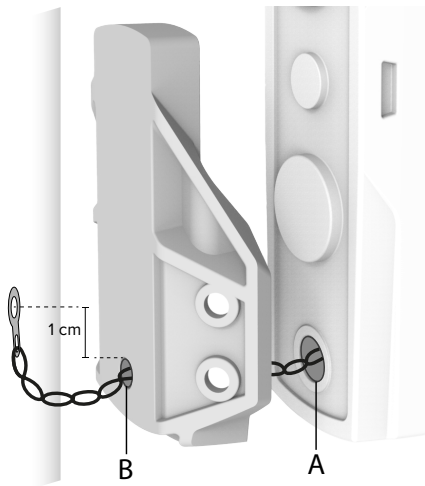

KSAS1013 kit (GREEN)

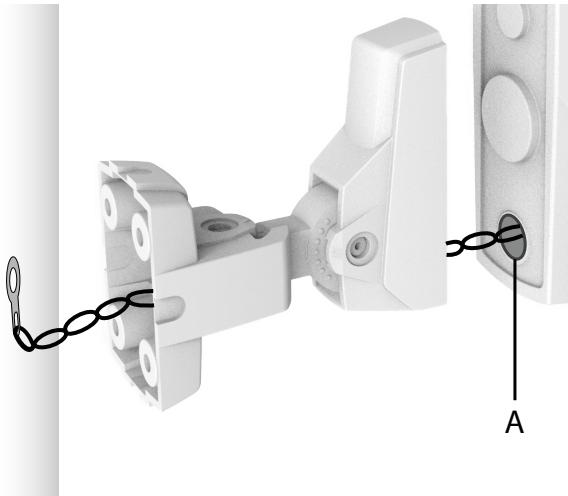

KSAS1032 kit (WHITE)

- drill a hole (diameter: 6,5 mm) on the detector base (A). If you are using the ANGSGX, drill a hole on it as well (B).
- feed the cable in the hole, from the eyelet end. If you are using the ANGSGX bracket or the SNDSGX swivel mount, feed the cable as illustrated above.
- fix a S4 dowel to the wall at a height of 1 cm from the hole
- fix the eyelet to the dowel
- fix the detector base (and also the bracket/swivel mount if this is the case) to the wall
- cut the wires to the required length

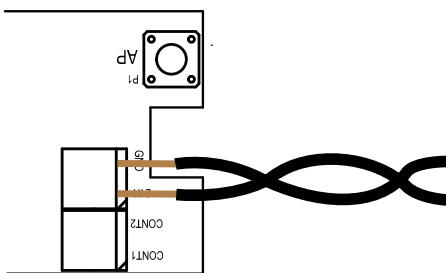

- connect the wires to the 24H terminals on board

## 6.1 First power up

- open the cover and position the battery as illustrated in the mounting procedure
- press and release 3-4 times Tamper button
- reset any discharged battery memory on control unit or compatible receiving device

**!** *If the battery is new or has not been used for long time, a wrong message of discharged battery may be displayed. Such problem depends on Lithium Thionyl Chloride battery chemical specifications and can be solved by carrying out the procedure illustrated above. If the battery has been exposed to low temperature, it is advisable to keep it at room temperature before installation.*

## 6.2 Device learning to NG-TRX control unit

STRIXO2K is acknowledged by the control unit as a detector with three channels that can be learned to three different zones.

The correspondence is as follows:

- Channel 1 = volumetric detector;
- Channel 2 = magnetic 1 / roll-up shutter 1 (default: magnetic);
- Channel 3 = magnetic 2 / roll-up shutter 2 (default: roll-up shutter).

Before starting learning procedure, remove the front cover (as illustrated in mounting procedure) to be able to access learn key P2.

**!** *Verify that the battery is charged otherwise the device will not be learnt.*

### Device learning procedure:

- on control unit keypad, enter installer code followed by **OK** to go to setup menu
- use arrow keys **↑** or **↓** to go to LEARN RADIO DET. option
- press **OK**
- use arrow keys to go to the zone to which learning the first channel of the device
- press **OK**
- press key 1 (saved to control unit)
- go to the detector
- press and hold detector learn key (P2) for 3 seconds: the detector has entered learning mode when the device blue LED blinks twice and buzzer beeps twice
- in case of wrong learning procedure, the unit will not confirm the procedure, the detector will beep once to signal error and the device blue LED will remain OFF: restart the procedure



- in case of correct learning procedure, the unit buzzer will beep twice and the device blue LED will switch on for 1 second
- once a channel has been learned, the menu will go to the next channel. Press OK to learn it, # to skip it. Channels that have not been learned here, can be learned later using BrowserOne application
- exit control unit setup menu. When required, press **OK** to save the setup

## 7 SETUP VIA BROWSERONE

The device can be set using BrowserOne v3.6.7 or above.

- load the latest module available for the control unit in use
- start control unit connection
- select **Read setup** key to read control unit setup
- select the grid row corresponding to the zone used to learn the device
- select tab **Radio Devices NG-TRX**

Zones	Areas	Outputs	Users	Telephone Dialler	System Options
	Zone Name		NG-TRX		
07	Zone 7		Yes		
08	Zone 8		Yes		
General		Assign Area/Sector	Radio Devices	Cable Devices	Radio Devices NG-TRX

### 7.1 NG-TRX options

Detectors parameters common to all channels. For detailed information, please see programming manual of the control unit in use.

Buzzer activation Buzzer disabled

Performance tuner Automatic

Supervision interval 5 min

Delay supervision anomaly

Tx Boost

- ▼ **Buzzer activation**  
Enable device buzzer for alarm/reset.
- ▼ **Performance tuner**  
Adjust balance between consumption and power used for data transmission.
- ▼ **Supervision interval**  
Set time intervals for control unit data transmission in order to check device presence and proper working.
- ▼ **Delay supervision anomaly**  
If enabled, the anomaly caused by lack of supervision will be signalled with a delay equal to 6 times the supervision time.
- ▼ **Tx Boost**  
Option increasing transmission range (by 10÷30%,

effective increase); it may affect battery lifetime at the same time.

### 7.2 STRIXO2K detector options

Use this section to set specific parameters of STRIXO2K device.

- ▼ **Enable Led**  
If disabled, LED indicators will not blink in case of alarm/tamper (they will continue working in walk test or learning mode).
- ▼ **Buzzer activation functions**  
When enabled, buzzer settings set in **Buzzer activation** field in **Options NG-TRX** window above will be applied to the selected channel.

#### Channel 1

It can be associated to onboard PIR sensor only. If you want to change the channel, select the zone from dropdown menu, then select **Jump** button. Further options selectable:

- ▼ **Time inhibition**  
Time interval during which the detector will remain inhibited after an alarm transmission.
- ▼ **Range**  
Detection range of the device (25% = 2 m; 50% = 4 m; 75% = 6 m; 100% = 8 m).
- ▼ **Sensitivity**  
Number of pulses to be detected before entering the alarm condition. **Normal:** 2 IR + 4 MW pulses; **maximum:** 1 IR + 2 MW pulses.
- ▼ **Antidazzle**  
Enable/disable anti-blind function (default: disabled). If enabled, in case of blinding attempts, a fault event will be sent together with a tamper or alarm event according to options selected in drop-down menu **Antidazzle Echo**.

#### Channel 2 and 3

They can be associated to magnetic contacts or rollup shutter sensors (fast).

If you want to change the channel, select the zone from dropdown menu, then select **Jump** button. In **Type** drop-down menu select **Magnetic** or **Fast**. With **Fast** selected, set also Time (interval within pulses have to be counted) and **Sensitivity** (number of pulses).

### 7.3 Options for communication to control unit

To configure communication between NG-TRX devices and control unit:

- on BrowserOne main page, select **System Options**
- select tab **Options NG-TRX**

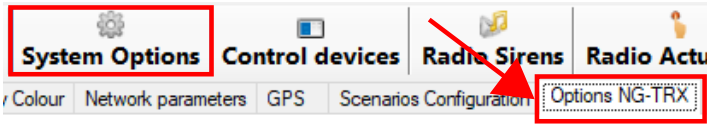

#### ▼ Receiving multichannel

When active, the control unit receives on three channels simultaneously; when deactivated, the control unit receives on one channel only (preset/preferred). We recommend to keep it non active only if a channel has disturbances.

#### ▼ Default channel

This is the channel used by the control unit to receive data in case of no interference (default: channel 1). In case of interference, the unit defines a channel (even different from the preset one) according to interference level and uses it for data reception.

#### ▼ Supervision interval

It defines supervision time interval common to all system devices: such interval will be valid for all devices that has no specific interval selected (default).

Select **Enable detection RF interference** to allow the control unit to detect any interference on the three radio channels.

For further information about this option and other in this menu, please see programming manual of the control unit in use.

 *Once all changes have been done, write the new setup to the control unit. It will be sent to STRIXO2K at the first valid transmission and the device will beep to confirm the operation.*

## 8 OPERATING MODE

The detector detects motion inside the covered area.

### 8.1 Operating sequence

#### 1. Stabilisation

After power on, the device takes around 25 s to stabilize.

#### 2. Walk test

The device remains in walk test mode for 8 minutes. The green LED blinks for each IR pulse received.

When IR section detects the number of IR pulses set, it enters pre-alarm mode for 5s.

If within this time interval the set number of MW pulses is counted (each signalled by the blue LED) the device will generate and send an alarm event, otherwise it will go back to standby mode.

After an alarm event is transmitted in walk test mode the device will remain inhibited for 5 seconds.

### 3. Standard operating mode

When walk test is finished (8 minutes) the device enters operating mode.

Detection mode is the same as in walk test, except that pulses are not signalled and blue LED will switch on only when the general alarm is transmitted.

When operating, after an alarm transmission, the device will remain inhibited:

- for 5 s if the detector belongs to armed sectors (only for the first three alarms received inside an arming cycle);
- for the time set if the detector belongs to disarmed sectors (or starting from the fourth alarm received inside an arming cycle).

When in operation, there are two ways to restart walk test:

1. switching the detector off and on, waiting until it is stabilized
2. on control unit keypad, enter installer code and select **SYSTEM TEST > ZONES TEST**

### 8.2 Warnings before system arming

- Close shutters / roll-up shutters before arming the system.
- In case of system arming with shutters / roll-up shutters open, do consider that people or animals passing very close to protected doors/windows (less than 20 cm) may be detected.
- Close indoor windows/French windows in order to avoid vibrations caused by the wind or inside-outside air passage.
- Roll up insect screens.

### 8.3 Anti-blinding function

STRIXO2K features anti-blinding function.

The function detects blinding attempts made by placing a reflective body before the lens.

The function can be activated via BrowserOne.

When blinded, the detector will send a "fault" event together with an "alarm" or "tamper" event (according to selections in **Antidazzle Echo** drop-down menu).

 *If the option "fault + tamper" is selected, the blinding attempts detected will activate sirens too.*

 *We recommend to disable this function if the detector is installed in crowded places, with people passing at less than 20 cm distance.*

When the reflective body is removed, the standard operating mode will be restored.

### 8.4 LED indications

Condition		Green LED	Blue LED
Power on	Stabilisation	Fixed 25 s	Fixed 25 s

Condition		Green LED	Blue LED
Walk test	IR pulse	Single blinking	
	MW pulse		Single blinking
	Pre-alarm IR	ON steady	
	Pre-alarm MW		ON steady
	Alarm transmission	ON 1.5 s	ON 1.5 s
	Blinding	Multiple blinking	
Operating	Volumetric alarm transmission		ON
	Transmission of magnetic contacts / roll-up shutter alarms	ON	
	Blinding	Multiple blinking	
	Tamper	ON 1.5 s	ON 1.5 s

LED indications.

### 9.3 Battery replacement

Replace the battery with a new one of the same type only. Follow this procedure:

- Open the housing (see mounting procedure).
- Remove battery connector. Remove discharged battery.
- Press and release 3-4 times Tamper button to discharge any capacitor that may still be charged.
- position the new battery (see mounting procedure).
- Reset any discharged battery memory on control unit or compatible receiving device.

Discharged batteries shall be disposed of according to current laws and using specific containers.

Materials used are very harmful and polluting if dispersed in the environment.

## 9 MAINTENANCE



### 9.1 System test mode

To start this function, go to unit menu **SYSTEM TEST > ZONE TEST**.

Device operating mode is the same as in walk test, except that device buzzer is activated upon any alarm.

The detector will pass to “detector test” mode only after the first correct transmission has been performed; it could take up to 5 min (default) from ZONES TEST start.

 *A long permanence in zones test mode may reduce battery lifetime.*

### 9.2 Periodic test

Carry out a simple test regularly to verify the functionality and the coverage limits of the detector.

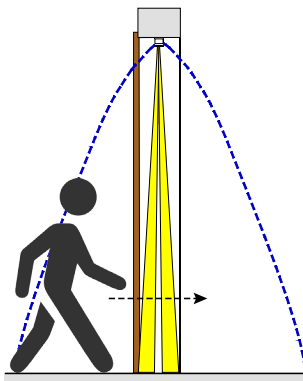

- set the device in system test mode (see above)
- pass through the detector protected area, in both directions. Pass through the access door to the end of it.

Detector LED indicator shall respond as shown in the table

## EU DECLARATION OF CONFORMITY

Hereby, EL.MO. Spa declares that the radio equipment STRIXO2K is in compliance with Directive 2014/53/EU.

The full text of the EU declaration of conformity is available at the following internet address: [www.elmospa.com](http://www.elmospa.com) – registration is quick and easy.



## GENERAL WARNINGS



This device has been designed, built and tested with the utmost care and attention, adopting test and inspection procedures in compliance with current legislation. Full compliance of the working specifications is only achieved in the event the device is used solely for its intended purpose, namely:

**Indoor/outdoor wireless DT detector with vertical curtain coverage for NG-TRX intrusion detection systems.**

The device is not intended for any use other than the above and hence its correct functioning in such cases cannot be assured. Consequently, any use of the manual in your possession for any purpose other than those for which it was compiled - namely for the purpose of explaining the product's technical features and operating procedures - is strictly prohibited.

Production processes are closely monitored in order to prevent faults and malfunctions. However, the components adopted are subject to an extremely modest percentage of faults, which is nonetheless the case with any electronic or mechanical product.

Given the intended use of this item (protection of property and people), we invite you to adapt the level of protection offered by the system to suit the actual situation of risk (allowing for the possibility of impaired system operation due to faults or other problems), while reminding you that there are specific standards for the design and production of systems intended for this kind of application.

**We hereby advise you (the system's operator) to see that the system receives regular routine maintenance, at least in accordance with the provisions of current legislation, and also check on as regular a basis as the risk involved requires that the system in question is operating properly, with particular reference to the control unit, sensors, sounders, dialler(s) and any other device connected. You must let the installer know how well the system seems to be operating, based on the results of periodic checks, without delay.**

Work involved in the design, installation and maintenance of systems incorporating this product should be performed only by personnel with suitable skills and knowledge required to work safely so as to prevent any accidents. It is vital that systems be installed in accordance with current legislation. The internal parts of certain equipment are connected to the mains and therefore there is a risk of electrocution when maintenance work is performed inside without first disconnecting the primary and emergency power supplies. Certain products include batteries, rechargeable or otherwise, as an emergency backup power supply.

If connected incorrectly, they may cause damage to the product or property, and may endanger the operator (explosion and fire).

## INSTALLER WARNINGS



Comply strictly with current standards governing the installation of electrical systems and security systems, and with the manufacturer's directions given in the manuals supplied with the products.

Provide the user with full information on using the system installed and on its limitations, pointing out that there are different levels of security performance that will need to suit the user's requirements within the constraints of the specific applicable standards. See that the user looks through the warnings given herein.

Work involved in the design, installation and maintenance of systems incorporating this product should be performed only by personnel with suitable skills and knowledge required to work safely so as to prevent any accidents. It is vital that systems be installed in accordance with current legislation. The internal parts of certain equipment are connected to the mains and therefore there is a risk of electrocution when maintenance work is performed inside without first disconnecting the primary and emergency power supplies. Certain products include batteries, rechargeable or otherwise, as an emergency backup power supply.

If connected incorrectly, they may cause damage to the product or property, and may endanger the operator (explosion and fire).

## USER WARNINGS



Check the system's operation thoroughly at regular intervals, making sure the equipment can be armed and disarmed properly.

Make sure the system receives proper routine maintenance, employing the services of specialist personnel who meet the requirements prescribed by current regulations.

Ask your installer to check that the system suits changing operating conditions (e.g. changes in the extent of the areas to be protected, change in access methods, etc...)

## MAIN SAFETY RULES

The use of the device is forbidden for children and unassisted disabled individuals.

Do not touch the device when bare footed, or with wet body parts. Do not directly spray or throw water on the device.

Do not pull, remove or twist the electric cables protruding from the device even if the same is disconnected from the power source.

## DISPOSAL WARNINGS



IT08020000001624

In accordance with Directive 2012/19/EU on waste electrical and electronic equipment (WEEE), please be advised that the EEE was placed on the market after 13 August 2005 and must be disposed of separately from normal household waste.

This product needs batteries for correct functioning. Exhausted batteries have to be delivered to dumping grounds authorized for battery collection. The materials used for this product are very harmful and polluting if dispersed in the environment.