



STAFFA

EASY

code: **STAFFAEASY**



IT STAFFA EASY è un sistema di bloccaggio in nylon di alta qualità, per cremagliere in ferro. Ha la possibilità di essere installata in verticale oppure in orizzontale.

UK STAFFA EASY is a nylon blocking system that facilitate the installation of the iron rack on sliding gates. Can be fitted vertically or horizontally.

FR STAFFA EASY est un système de blocage en nylon de grande qualité pour crémaillère en fer. Il est possible de l'installer en position verticale ou horizontale.

DE STAFFA EASY ist ein qualitativ besonders hochwertiges Sperrsystem aus Nylon für Zahnstangen aus Metall. Horizontal oder vertikal montierbar.

ES STAFFA EASY es un sistema de bloqueo de nailon de alta calidad para cremalleras de hierro. Es posible instalarlo en posición vertical u horizontal.

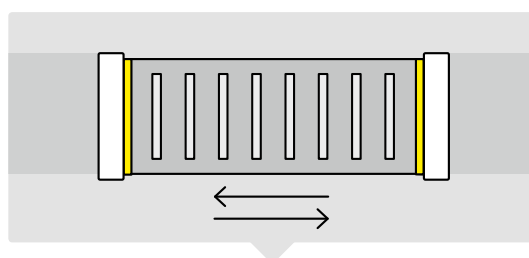

APPLICATIONS

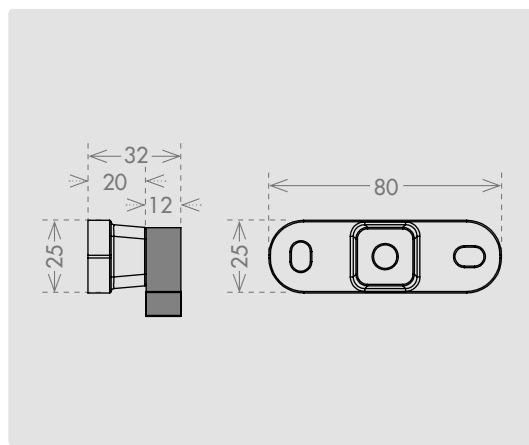

SIZES



MAX LOAD

LEGENDA

APPLICAZIONI / APPLICATIONS APPLICATIONS/ ANWENDUNGEN / APLICACIONES

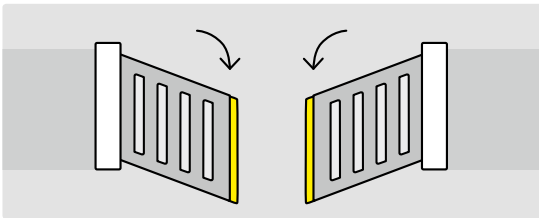

Cancelli a battente.
Swing gates.
Portails battants.
Schwenktore.
Puertas de hoja batiente.

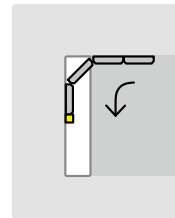

Portoni sezionali.
Sectional doors.
Portes sectionnelles.
Sektionaltore.
Portones seccionales.

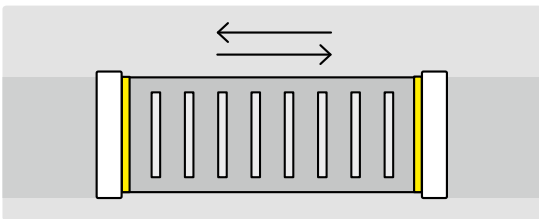

Cancelli scorrevoli.
Sliding gates.
Portails coulissants.
Schiebetore.
Puertas correderas.

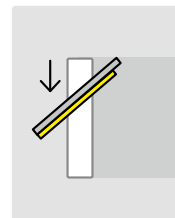

Portoni basculanti.
Overhead doors.
Portes basculantes.
Kipptore.
Portones basculantes.

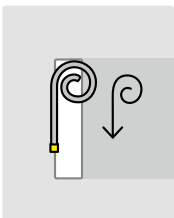

Serrande.
Rolling shutters.
Rideaux.
Rolltore.
Puertas enrollables.

CARATTERISTICHE GENERALI / GENERAL SPECIFICATIONS CARACTERISTIQUES GENERALES / ALLGEMEINE DATEN / CARACTERÍSTICAS GENERALES

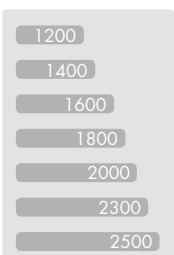

Lunghezze disponibili.
Available lengths.
Longueurs disponibles.
Verfügbare Längen.
Largos disponibles.

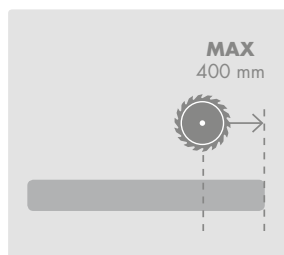

Accorciabilità massima.
Maximum trimming lengths.
Raccourcissement maximum.
Maximale Ablängbarkeit.
Recorte máximo posible.

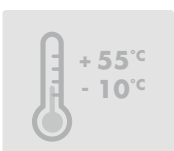

Temperatura di esercizio.
Working temperature.
Température de fonctionnement.
Betriebstemperatur.
Temperatura de funcionamiento.



Grado di protezione microinterruttori.
Microswitch degree of protection.
Indice de protection des micro interrupteurs.
Schutzart Mikroschalter.
Grado de protección de los microinterruptores.

CARATTERISTICHE MODELLO / MODEL SPECIFICATIONS CARACTERISTIQUES PRODUITS / MODELLSPEZIFISCHE DATEN CARACTERÍSTICAS DEL MODELO



Contatto normalmente aperto (N.A.)
Normally open contact (N.O.)
Contact normalement ouvert (N.O.)
SchlieÙerkontakt (N.O.)
Contacto normalmente abierto (N. A.)



Contatto normalmente chiuso (N.C.)
Normally closed contact (N.C.)
Contact normalement fermé (N.F.)
Öffnerkontakt (N.C.)
Contacto normalmente cerrado (N. C.)



Dispositivo di sicurezza resistivo.
Resistive safety edge.
Dispositif de sécurité résistif.
Widerstands-Schutzvorrichtung.
Dispositivo de seguridad resistivo.



Certificato IMQ.
Certificated by IMQ.
Certificat IMQ.
Zertifiziert durch IMQ als Prüfinstitut.
Certificación IMQ.



Portata massima in campo aperto.
Open field maximum range.
Portée maximum en champ libre.
Maximale Reichweite ungestört.
Alcance máximo en campo abierto.



Canali di trasmissione.
Nr. of transmission channels.
Canaux de transmission.
Übertragungskanäle.
Canales de transmisión.



Comanda fino a ... TX.
Controls up to ... Tx.
Contrôle jusqu'à ... TX.
Betätigung von bis zu ... Sendern.
Controla hasta ... TX.



Alimentazione con batterie al litio 1,5 V.
1,5V lithium batteries transmitter power supply.
Alimentation par piles au lithium 1,5 V.
Stromversorgung durch Lithiumakkus 1,5 V.
Alimentación con pilas de litio de 1,5 V.



Alimentazione 12/24 v AC/DC.
12/24 v AC/DC Power supply.
Alimentation 12/24 v AC/DC.
Betriebsspannung 12/24V AC/DC.
Alimentación: 12/24 VCA/VCC.



Frequenza di trasmissione.
Transmission frequency.
Fréquence de transmission.
Übertragungsfrequenz.
Frecuencia de transmisión.



Collegamento in serie di più coste conduttive.
Series wiring of several conductive safety edges.
Installation de plusieurs palpeurs conducteur en série.
Reihenschaltung mehrerer Kontakteleiste
Conexión en serie de mas dispositivos CND.

OPZIONI / OPTIONALS OPTIONS / OPTIONEN / OPCIONES



Scheda di controllo.
Control boards.
Carte de contrôle.
Steuerkarte.
Tarjeta de control.

OPT



Coppia trasmettitore + ricevitore wireless.
Wireless receiver&transmitter.
Couple transmetteur et récepteur sans fil.
Funk-Sender-/Empfängeranlage.
Conjunto de transmisor + receptor inalámbrico.

OPT



Ricevitore wireless.
Wireless receiver.
Récepteur sans fil.
Funkempfänger.
Receptor inalámbrico.

OPT