

IGEM 5000G

WEATHERPROOF ELECTROMAGNET

Stainless Steel:

Hi-quality built compact electromagnet finished in strong AISI 304 stainless steel for standard door applications. The unit is supplied completely sealed to allow external applications.

Quality, Security and Design:

The IGEM 5000G is a unique electromagnet lock providing higher security because of its quality, non-corrosive material and robustness.

Security and design are guaranteed thanks to its stainless steel brushed finish and top of the range metal material, with no residual magnetism.

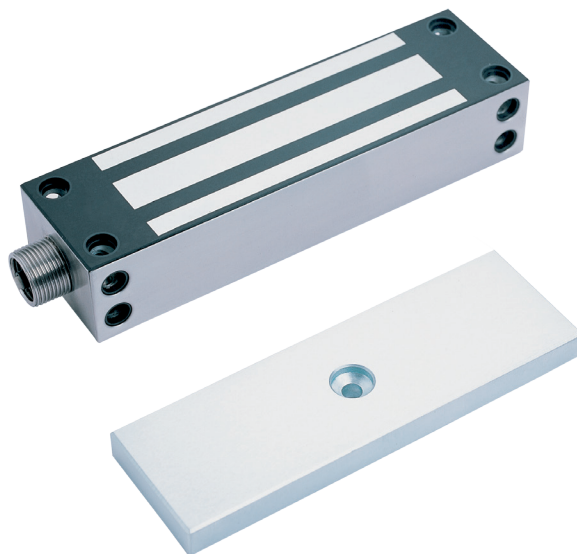

FEATURES

- 7500N Range
- High-quality stainless steel*
- IP 67 compliant: Housing and wiring completely sealed
- Corrosion proof: Salt spray test. ISO 9227, ASTM B-117 90
- No residual magnetism – No spring push button on armature plate for magnet release
- All components and connections fully sealed
- Built-in MOV surge protection
- 10 years warranty

* AISI304 stainless steel and AISI316 available on demand

Heavy Duty External Use - IP 67

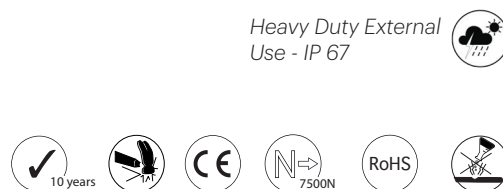

DIMENSIONS

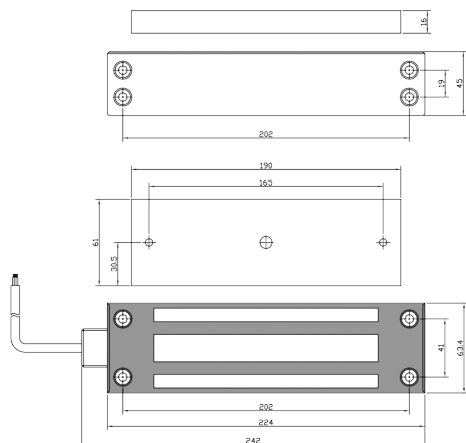

SPECIFICATIONS

- Mounting: Universal
- Holding force real tested* (+/-10%): ~7300 N/ ~1640 lbf/~750 kgf
- Voltage: 12/24 V DC
- Current: 500/250 mA
- Locking monitoring: Yes
- Size (LxWxH): 225 x 63 x 44 mm (exc. side conduit)
- Weight: ~5 kg
- Operating temperature: -40°C to + 60°C

* According tests of range done in independent laboratory.