

EN

Solexa 230V

Shading Control

Item numbers 10110, 10130, 10131

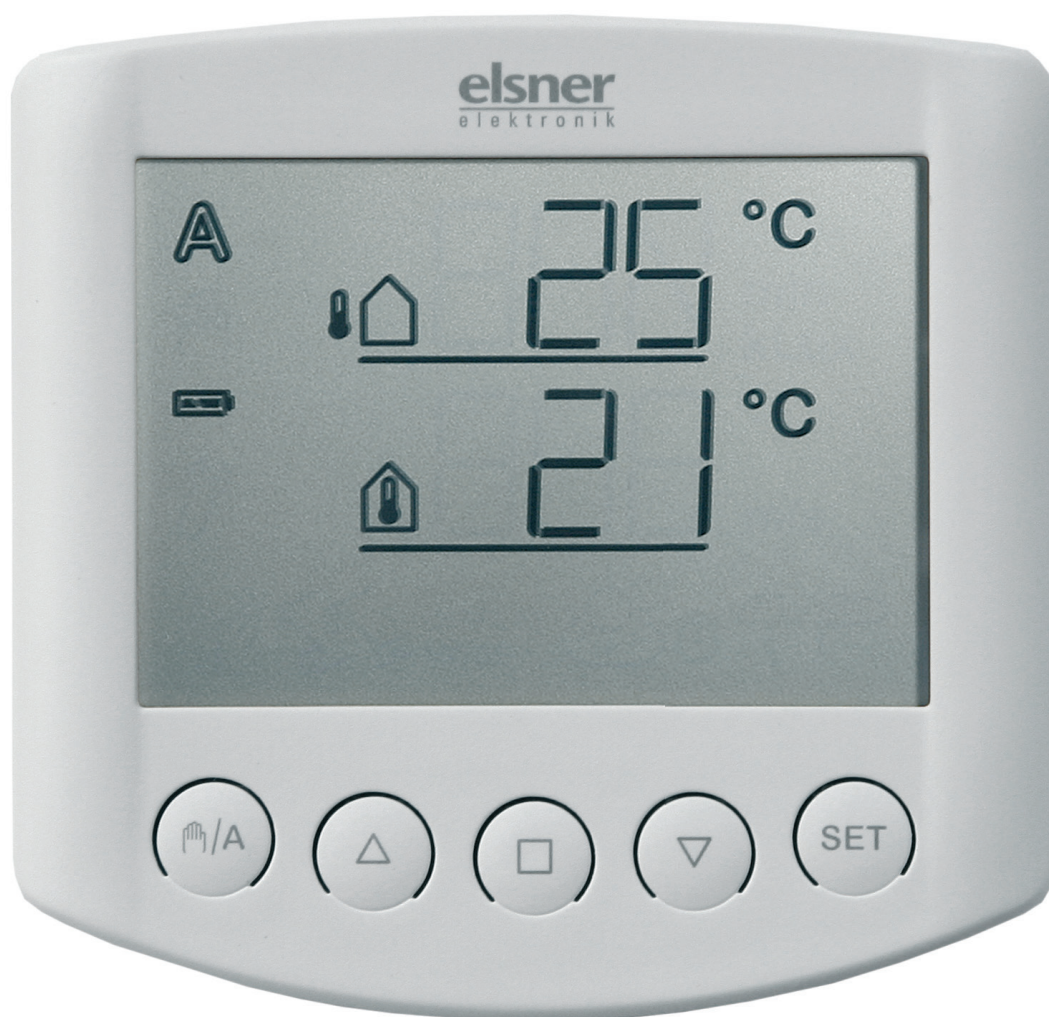

elsner

Installation and Adjustment

Description	3
Scope of supply	3
Commissioning procedure.....	3
Options for connection and control.....	3
Overview of available automatic functions	4
Operation	5
Key functions and display symbols of the meteorological data display.....	5
Display of lightness and wind speed	6
Manual operation	7
Move shading manually.....	7
Switch between manual and automatic.....	7
Central control	7
Settings (default setting, automatic)	8
Installation and Commissioning	9
Installation of weather station and connection of the drive mechanism.....	9
Position	9
View of rear side and drill hole plan for the weather station.....	10
Installing the weather station	10
Attaching the mount.....	12
Preparation of the weather station.....	13
Connection of voltage supply and drive mechanism	14
Mounting of the weather station	15
Details for the installation of the weather station	16
Installation of operating unit	16
View of rear side and drill hole plan for the operating unit	17
Notes on radio installations	18
Commissioning.....	19
Sensor testing.....	20
Sun sensor testing	20
Wind sensor testing	20
Rain sensor testing	21
Temperature sensor testing.....	21
Basic settings	22
1. Radio connection to the weather station	24
Delete all radio connections of the weather station.....	25
2. Rotational direction of the motor.....	26
3. Operating direction	27
4. Operating command in case of wind or rain alarm.....	28
5. Sending of meteorological and automatic data	29
6. Shading position	30
6.1. Retracted position.....	31
6.2. Setting of the desired position	31
6.3. Slat angle.....	32
7. Saving of basic settings	32

Setting of automatic	33
Safety instructions for automatic and alarm functions	35
A. Lightness for the shading	36
B. Extension delay	37
C. Retraction delay	37
D. Indoor temperature block	38
E. Outdoor temperature block	39
F. Wind alarm	40
Table for wind speeds.....	41
G. Rain alarm	41
H. Storage of automatic settings	42
Service	43
Service and maintenance	43
Weather station.....	43
Operating unit.....	43
Insert batteries (operating unit).....	43
Error messages.....	44
Query service data.....	45
Factory settings	46
Abbreviations	46
Technical data	46
Operating unit.....	46
Weather station.....	47
Connection diagram for weather station.....	48
Connection samples for several drive mechanisms as group.....	49
Connection samples for centralised control with IMMSG 230 compact.....	50
Personal setting data of the automatic	51

Solexa • from software version operating unit 4.2, Solexa weather station 4.2
Status: 11/05/2023. Errors excepted. Subject to technical changes.

Description

The Solexa shading control system has been developed for the automatic control of awnings or blinds and for comfortable manual operation. The control system offers a highest degree of flexibility for installation and setting and may therefore be adjusted individually to different conditions. Please use this instruction manual in order to adjust the automatic function to your requirements.

Scope of supply

- Weather station
- Operating unit (incl. 2 batteries)

Commissioning procedure

Installation, inspection, commissioning and troubleshooting of the control system must only be carried out by a competent electrician.



Proceed as follows when commissioning the Solexa control system:

1. Installation and connection (see chapter „Installation and commissioning“)
2. Basic setting (see chapter „Basic settings“)
3. Setting of the automatic (see chapter „Setting of automatic“)

Options for connection and control

A drive mechanism for awnings or blinds may be connected to the Solexa control system. If several awnings or blinds shall be controlled together, the connection via a group control relay is possible.

The connected drive (or drive group) may be operated manually with the operating unit. A suitable radio remote control (Remo 8) and a radio push-button interface (RF B2-UP) are available in addition (option).

An operating device and an additional remote control Remo 8 or a pushbutton interface RF-B2-UP can be operated with the weather station (maximum two radio controlled participating devices at the weather station).

The following **environmental parameters** are measured and displayed:

- Outdoor and indoor temperature
- Lightness
- Wind speed
- Precipitation

Overview of available automatic functions

- Shading according to sun intensity with extension and retraction delay
- Extension to a programmed position; for blinds with slats with additional setting of the slat angle.
- Blocking of shading until a selectable indoor temperature is reached (heat gain, only in automatic mode)
- Retraction of shading below a selectable outdoor temperature (frost protection, only in automatic mode)
- Retraction of shading when a selectable wind speed is reached (wind alarm, function may be deactivated)
- Retraction of shading in case of rain (rain alarm, function may be deactivated)

The awning or blind is retracted in automatic mode after the set lightness value falls below or in case of rain/wind alarm.

The wind and rain protection functions are also active in manual mode if they have been set in automatic.

Operation

Key functions and display symbols of the meteorological data display

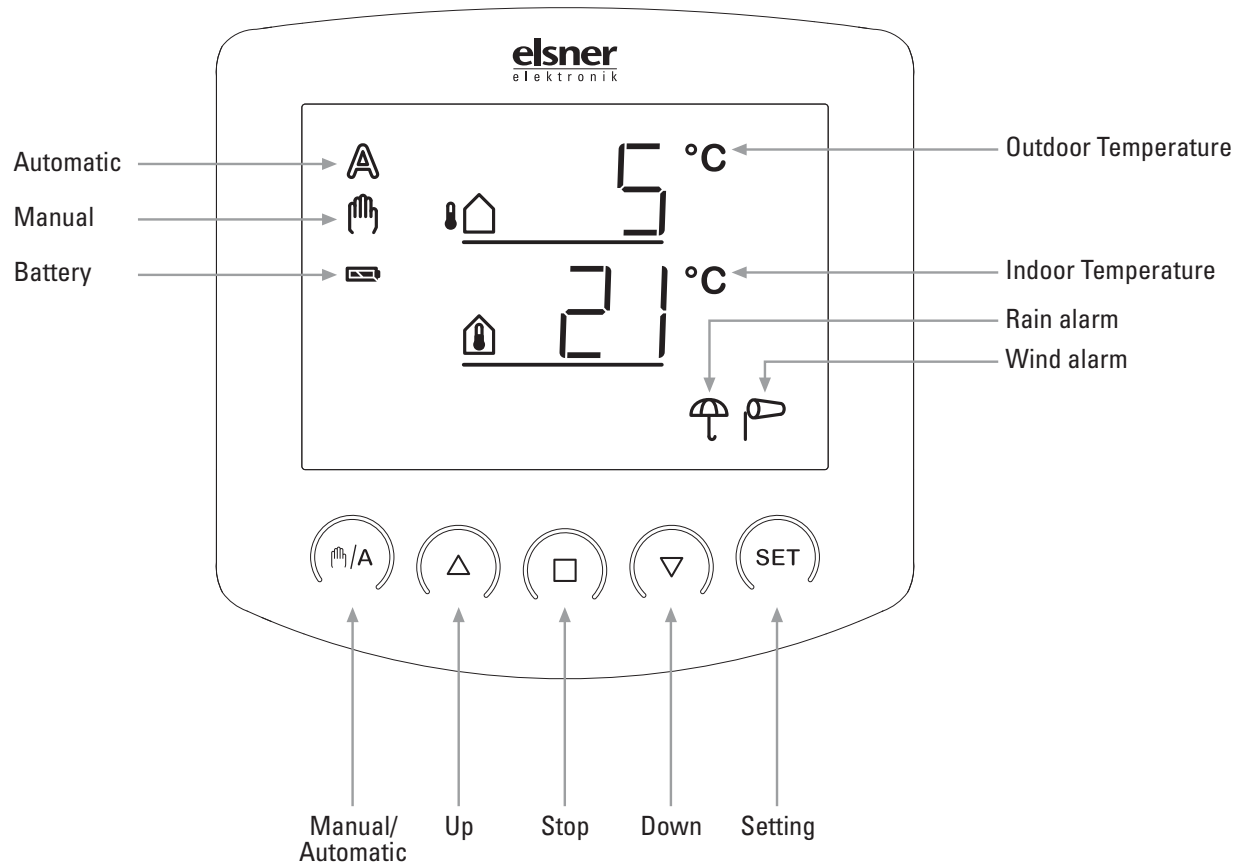

The basic position of the operating unit of the control system displays the current outdoor temperature (upper line) and the indoor temperature (lower line) as well as the function mode (automatic or manual), the battery load and the current alarm messages for rain or wind. The meteorological data are updated once per minute (and in case of a keystroke).



Outdoor temperature



Indoor temperature



Battery symbol (indicates the charge status of the battery) - full



- half full



- empty



Automatic mode activated



Manual mode activated. The connected drive mechanism was operated manually (with arrow keys) or /▲ key was pressed. Thus, the automatic functions are deactivated, there is no control in terms of lightness or temperature. The safety functions rain alarm and wind alarm are still activated. The control is in manual mode until you change to automatic mode with /▲ key.



Rain alarm. Exterior awnings are retracted, manual operation is blocked. The rain protection function may be turned on and off in the automatic settings (e.g. for internal awnings or blinds).



Wind alarm. Exterior awnings or blinds are retracted, manual operation is blocked. The wind protection function may be set up or turned off in the automatic settings (e.g. for internal awnings).

Display of lightness and wind speed

Press the SET key during temperature display once for a short moment, and current lightness (in kilolux, kLux) and wind speed (in meters per second, m/sec) are displayed. The values are updated every 4 seconds.

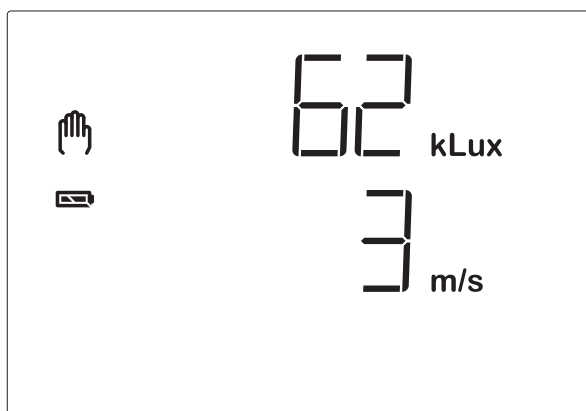

Note: During the first approx. 90 seconds after the return of voltage at the weather station, the wind value is not displayed correctly (e.g. after a power fail or in case of a first start). Therefore, manual operation is blocked in this period of time in case of activated wind alarm.

If you press the SET key again for a short moment, you get back to the temperature display (or to the central command display, see next chapter). After approx. 60 seconds, the display switches automatically to the temperature display.

Manual operation

Manual control as well as the presetting of the automatic functions and the basic setting of the connected shading is accomplished with the keys of the operating unit.

Move shading manually



The connected awning or blind may be manually operated with the keys Δ , \square and ∇ . The arrow keys are provided with a time automatic. By short pressing (less than 1 second), the awning or blind may be exactly positioned. If the key is pressed more than 1 second, the drive mechanism moves automatically to the final position. If you press \square , the drive mechanism stops.

In case of rain or wind alarm, the manual operation is blocked.

Switch between manual and automatic



Manual/automatic



Key hand/A switches between automatic mode (display **A**) and manual mode (display hand). After the manual operation with the keys Δ , \square or ∇ , the control system is in manual mode. The automatic functions then are deactivated, there is no control in terms of lightness or temperature. With key hand/A , the control is reset to automatic (display **A**). After switching from manual to automatic mode, the drive remains in the position set manually. If the conditions for automatic shading *are not met*, the control retracts the hangings at the end of the retraction delay. If the conditions for shading *are met*, the control at first retracts the hangings at the end of the extension delay (4-minute reference movement). After that the shading position is initiated.

Central control

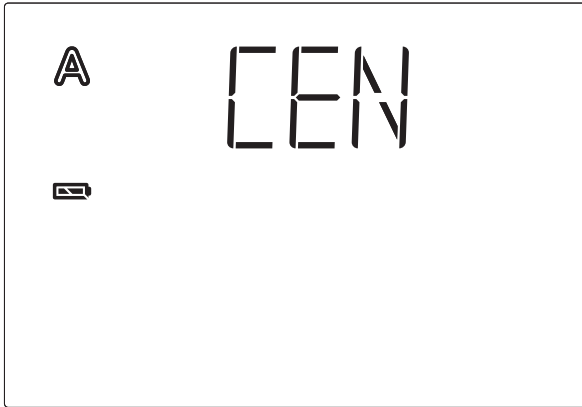
If the sending of meteorological data and automatic commands has been activated (see chapter 5 of the basic settings), you additionally obtain the following display after the manual mode:



In order to get to the display, press key /A twice shortly in automatic mode (A) and once shortly in manual mode ().

As long as the display shows CEN, manual operating commands of this operating unit are submitted to all drive mechanisms in system XS. During this display, use the keys ,  and  in order to centrally operate all drive mechanisms.

Settings (default setting, automatic)



With the **SET** key and by pressing shortly, you access the display of lightness and wind speed.

By pressing long, you access the setting menu of the automatic and the basic setting. For this purpose, please read chapters “Setting of automatic” or „Basic settings“.

Installation and Commissioning

DANGER!

Risk to life from live voltage (mains voltage)!



There are unprotected live components inside the device.

- Inspect the device for damage before installation. Only put undamaged devices into operation.
- Comply with the locally applicable directives, regulations and provisions for electrical installation.
- Immediately take the device or system out of service and secure it against unintentional switch-on if risk-free operation is no longer guaranteed.

Use the device exclusively for building automation and observe the operating instructions. Improper use, modifications to the device or failure to observe the operating instructions will invalidate any warranty or guarantee claims.

Operate the device only as a fixed-site installation, i.e. only in assembled condition and after conclusion of all installation and operational start-up tasks, and only in the surroundings designated for it.

Elsner Elektronik is not liable for any changes in norms and standards which may occur after publication of these operating instructions.

Installation of weather station and connection of the drive mechanism

Position

Select an assembly site at the building where wind, rain and sun may be collected by the sensors unobstructedly. Do not assemble any construction components above the weather station from where water may drop on to the rain sensor after it has stopped raining or snowing.

At least 60 cm of clearance must be left all around the weather station. This facilitates correct wind speed measurement without eddies. The distance concurrently prevents spray (raindrops hitting the device) or snow (snow penetration) from impairing the measurement. It also does not allow birds to bite it. Please ensure that the extended awning does not cast shade on the unit, and that this is not protected from the wind.

Temperature measurements can also be affected by external influences such as by warming or cooling of the building structure on which the sensor is mounted, (sunlight, heating or cold water pipes).

View of rear side and drill hole plan for the weather station

All values are in mm, deviations due to technical reasons are possible.

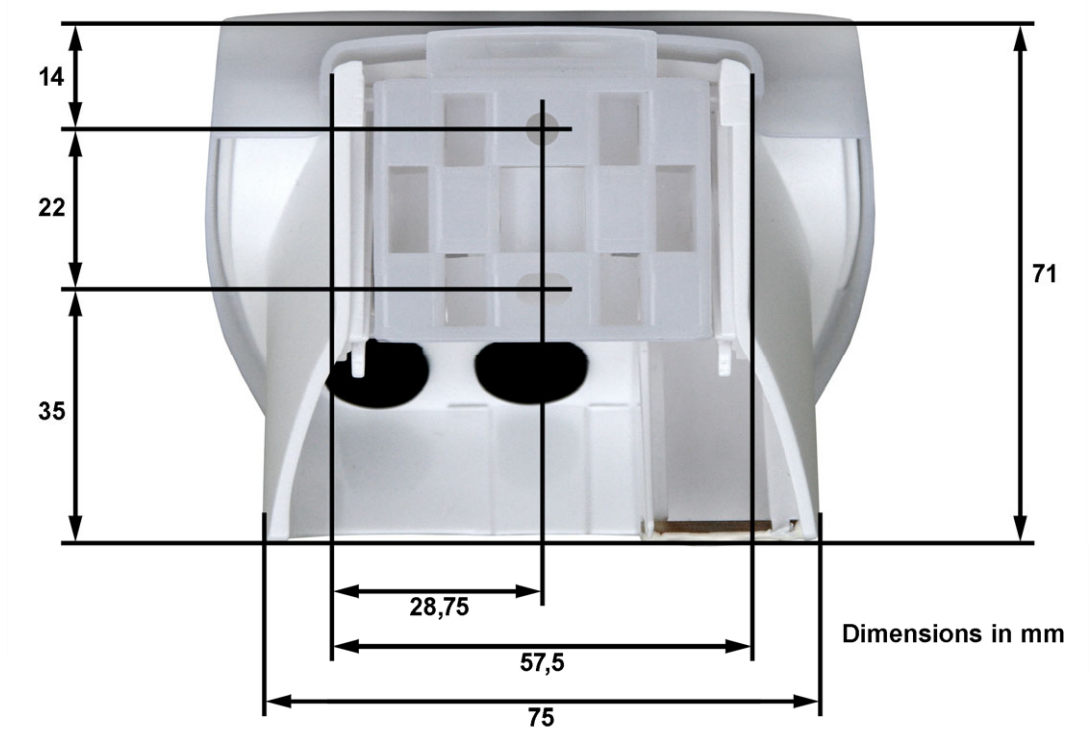

Installing the weather station

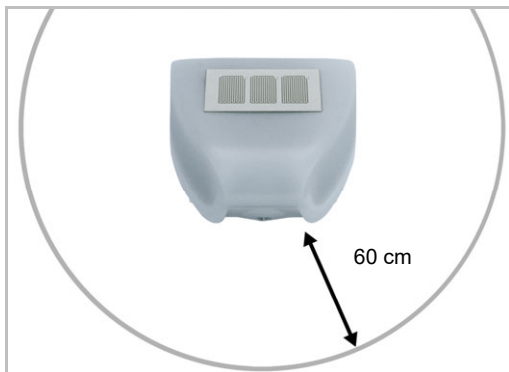

There must be at least 60 cm of space below, to the sides and in front of the weather station left from other elements (structures, construction parts, etc.).

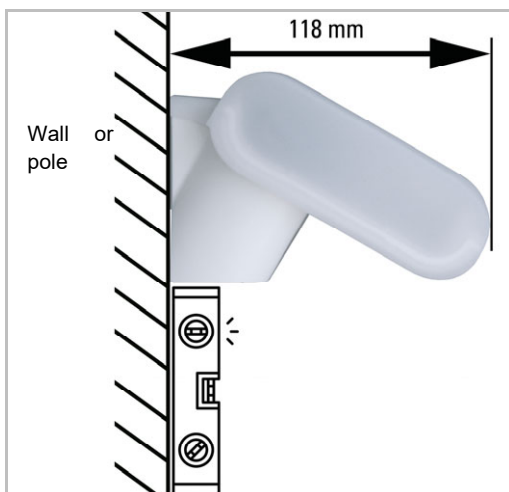

The weather station must be mounted on a perpendicular wall (or a pole).

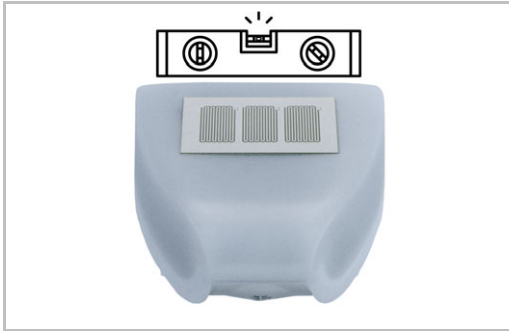

The weather station must be mounted in the horizontal transverse direction (horizontally).

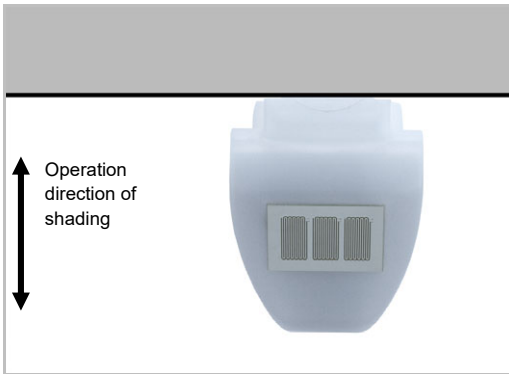

The weather station has to be aligned in operation direction of shading.

Attaching the mount

The weather station includes a combined wand/pole mount. On delivery, the mount is attached to the rear side of the housing with an adhesive strip.

Fasten the mount vertically onto the wall or pole.



When pole mounting: curved side on pole, collar downward.



When wall mounting: flat side on wall, crescent-shaped collar upward.

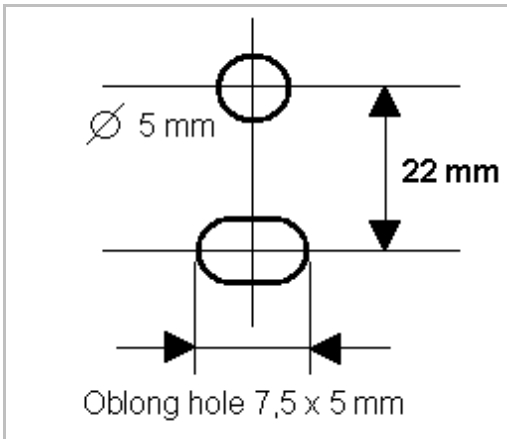

Drill sketch



An additional, **optional accessory** available from Elsner Elektronik is an articulated arm for flexible wall, pole or beam mounting of the weather station.

Example of the use of a mounting arm: Due to flexible ball joints, the sensor can be brought into ideal position.



Example for the application of the hinge arm mounting: With the hinge arm mounting, the weather station projects from beneath the roof. Sun, wind and precipitation can be measured unhindered by the sensors.



Example for the application of the hinge arm mounting: Pole-mounting with mounting brackets.

Preparation of the weather station

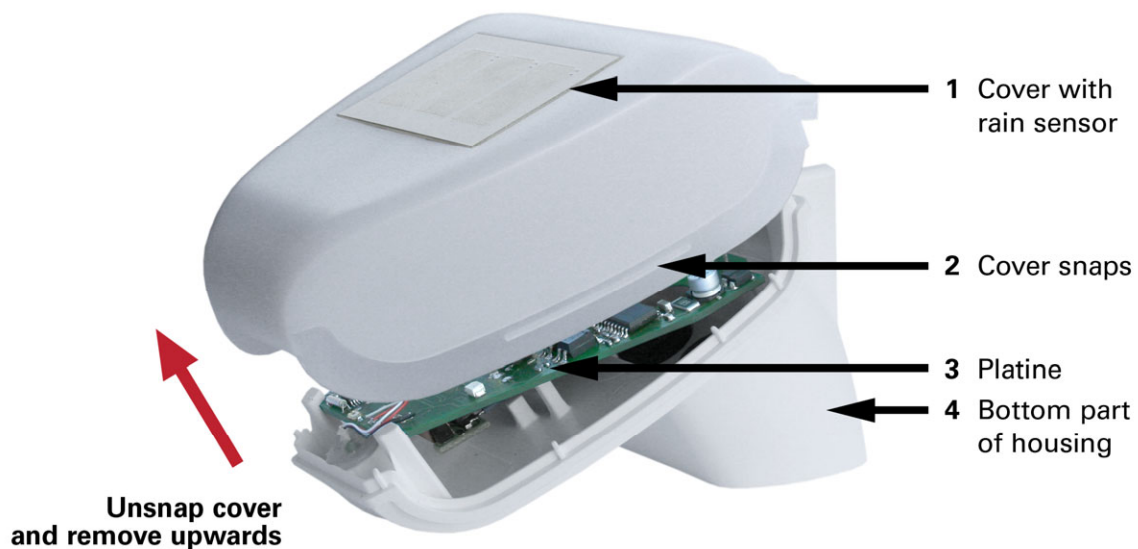

The cover of the weather station with rain sensor is engaged at the lower rim to the right and to the left (see fig.) Remove the cover from the weather station. Be careful not to break away the cable connection between the circuit board in the bottom part and the rain sensor in the cover.

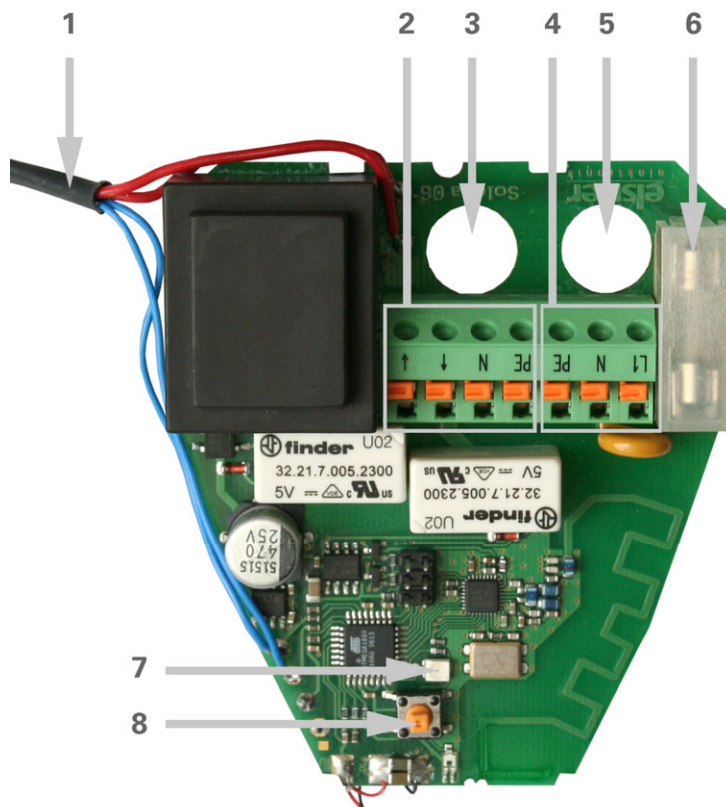

- 1 Cable connection to the rain sensor in the housing cover
- 2 Connections for the drive mechanism (tension clamp, PE/N/up/down), suitable for solid conductors up to 1.5 mm² or conductors with fine wires
- 3 Opening for the cable for the drive mechanism
- 4 Connections for voltage supply (230 V AC, tension clamp, L1/N/PE), suitable for massive conductors of up to 1.5 mm² or conductors with fine wires.
- 5 Opening for the cable for voltage supply
- 6 Microfuse 6.3 A
- 7 Programming LED. In normal operation, this LED indicates the receipt of a valid data package by a short flashing
- 8 Programming key for the teaching in of the radio connection to the operating unit

Connection of voltage supply and drive mechanism

The drive mechanism of the awning or blind is connected to the weather station. Several drive mechanisms may be connected in parallel. In case of the parallel connection of motors, please observe whether a group control relay is specified by the motor manufacturer. Group control relays may be provided by Elsner Elektronik or the motor manufacturer.

ATTENTION!

If motors are connected in parallel which are not suited for this purpose, both motor and control system are damaged.



Motors with a rated input of more than 1000 Watt must be operated with a relay or contactor with own feeder.

We offer appropriate power supply units for DC drive mechanisms. In case of need, please indicate the type of motor, manufacturer and – if available – technical data.

Pass the cable for voltage supply and drive mechanism through the rubber sealing at the bottom side of the weather station and connect voltage (L1/N/PE) and drive mechanism (PE/N/up/down) to the provided clamps.

Note: The programme button for the wireless connection is on the weather station board. To teach the wireless connection to the control unit, please see Chapter "Commissioning" and "1st Wireless Connection to the Weather Station" in the basic settings.

Close the housing by putting the cover over the bottom part. The cover must engage at the right and at the left with a clearly noticeable "click".

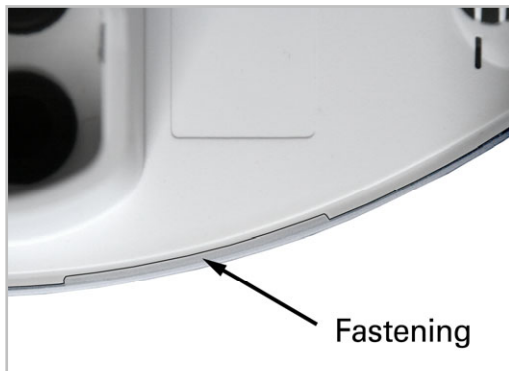

Check whether cover and bottom are correctly engaged! The figure illustrates the closed weather station from below.

Mounting of the weather station



Push the housing into the mounted holder from above. The journals of the holder must engage with the rails of the housing.

If you want to remove the weather station, you must pull it out of the holder in upwards direction against the resistance of the engagement.



After installation, remove the "Distance" notice sticker on the top of the cover.

Details for the installation of the weather station

Do not open the weather station if water (rain) might ingress: Even some drops might damage the electronic system.

Observe the correct installation. Wrong installation might destroy the weather station and the control electronics.

Please take care not to damage the temperature sensor (small circuit board at the bottom part of the housing.) when mounting the weather station. Please also take care not to break away or bend the cable connection between the circuit board and the rain sensor when connecting the weather station.

Installation of operating unit

The operating unit may be installed and operated in dry interior rooms only.



The operating unit is battery-powered and communicates with the weather station per radio.

When you select the assembly site, please avoid direct sun because this would distort the measurements of the indoor temperature. The appropriate sensor is integrated in the lower part of the operating unit. For the same reason, the operating unit should not be installed above the heater. Please make also sure that there is no direct air supply coming from windows or doors which would distort measured values.

View of rear side and drill hole plan for the operating unit

All values are in mm, deviations due to technical reasons are possible.

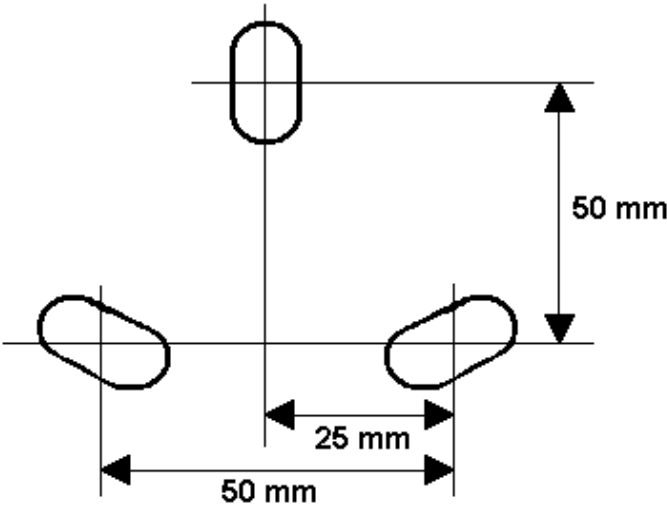
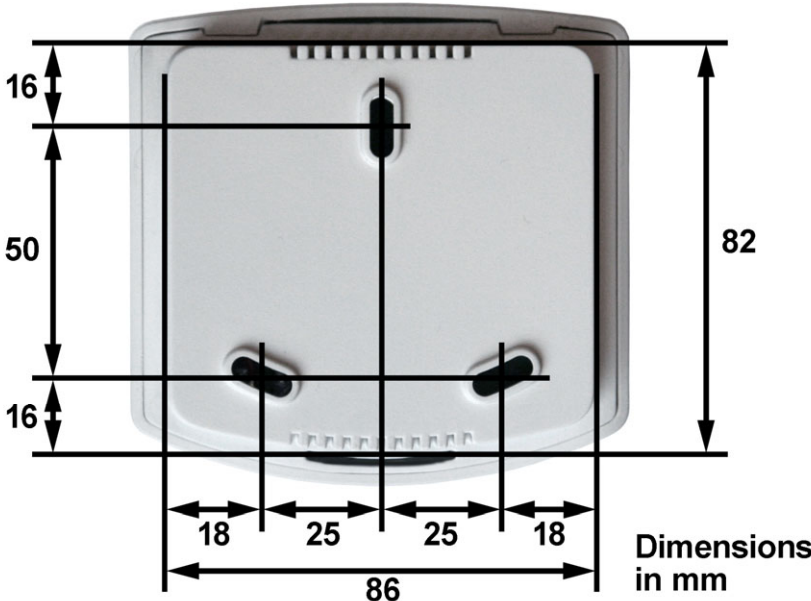

3 x Oblong hole 13 x 5 mm

Notes on radio installations

When planning facilities with devices that communicate via radio, adequate radio reception must be guaranteed. The range of wireless control will be limited by legal regulation and structural circumstances. Avoid sources of interference and obstacles between receiver and transmitter, that could disturb the wireless communication. Those would be for example:

- Walls and ceilings (especially concrete).
- Metal surfaces next to the wireless participants (e. g. aluminium construction of a conservatory).
- Other wireless devices and powerful local transmitters (e.g. wireless headphones), which transmit on the same frequency (868,2 MHz). Please maintain a minimum distance of 30 cm between wireless transmitters for that reason.

Commissioning

ATTENTION!

If a device is brought from a cold to a warm area, condensation can form. Before starting the device up, please ensure there is no moisture inside it (if necessary leave to dry).



After the system has been wired and the connections have been checked, please proceed as follows:

- Switch on the power supply voltage of the weather station.
- Insert batteries in the operating unit as described in chapter “Insert batteries”.
- The display of the operating unit now indicates that the radio connection between weather station and operating unit is not taught in.

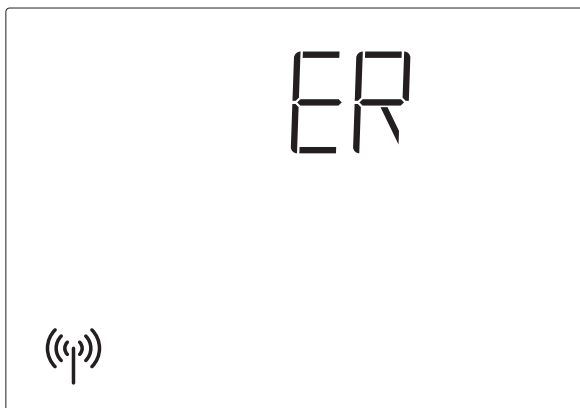

- Press SET key for 3 seconds until the following display appears:

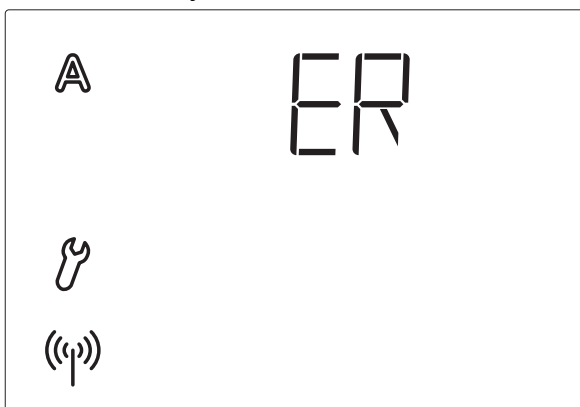

- Press SET again for 3 seconds until the display for the teaching in of the radio connection appears.



Now you are in basic settings. Proceed as described in the basic settings chapter „1. Radio connection to weather station“ (p. 20).

- Then check the function of the sensors (see next chapter).

Sensor testing

In case of malfunctions of the sensors, the display shows error messages instead of values. Please observe the chapter „Error messages“ on this.

Sun sensor testing

By the short pressing of the SET key on the operating unit you get to the lightness display (see chapter "Display of lightness and wind speed"). The upper value indicates the intensity of lightness in kilolux (kLux).

The sun sensor is located beneath the frosted glass cover of the weather station. If lightness is not sufficient, you must illuminate the weather station from above with a powerful torch until a value is indicated.

Wind sensor testing

By the short pressing of the SET key on the operating unit you access the wind speed display (see chapter "Display of lightness and wind speed"). The lower value indicates the speed in meters per second (m/s). The sensor pipe is on the front side at the bottom part of the weather station. If you blow in there, the value in the display changes.



Note: During the first approx. 90 seconds after the return of voltage at the weather station, the wind value is not displayed correctly (e.g. after a power fail or in case of a first start).

Rain sensor testing

Humidify one or several of the golden sensor areas in the cover of the weather station.

The  symbol (rain alarm) appears in the display. For this purpose, the rain alarm in the automatic settings must be activated (this is the presetting as delivered, also see chapter "G. Rain alarm"). Please observe that the rain message is maintained for 5 minutes after the drying of the sensor.

Temperature sensor testing

If reasonable values are displayed next to the symbols  (outdoor temperature) and  (indoor temperature), a correct function may be assumed.

Basic settings



These are the basic settings of the device for the commissioning of the control system. The following settings are queried one after the other:

1. Radio connection to the weather station
2. Rotational direction of the motor
3. Operating direction
4. Operating command in case of wind or rain alarm
5. Sending of meteorological and automatic data
6. Shading position
7. Save

This is how you access the basic settings:



In meteorological data display, press the SET key for at least 3 seconds in order to access the automatic setting.

You are in the automatic settings as soon as the symbols  and  are indicated left in the display.



Then press again SET for at least 3 seconds in order to access the basic settings.

You are in the basic settings as soon as the symbol  is indicated left in the display and as soon as you can see the first setting step (radio connection).

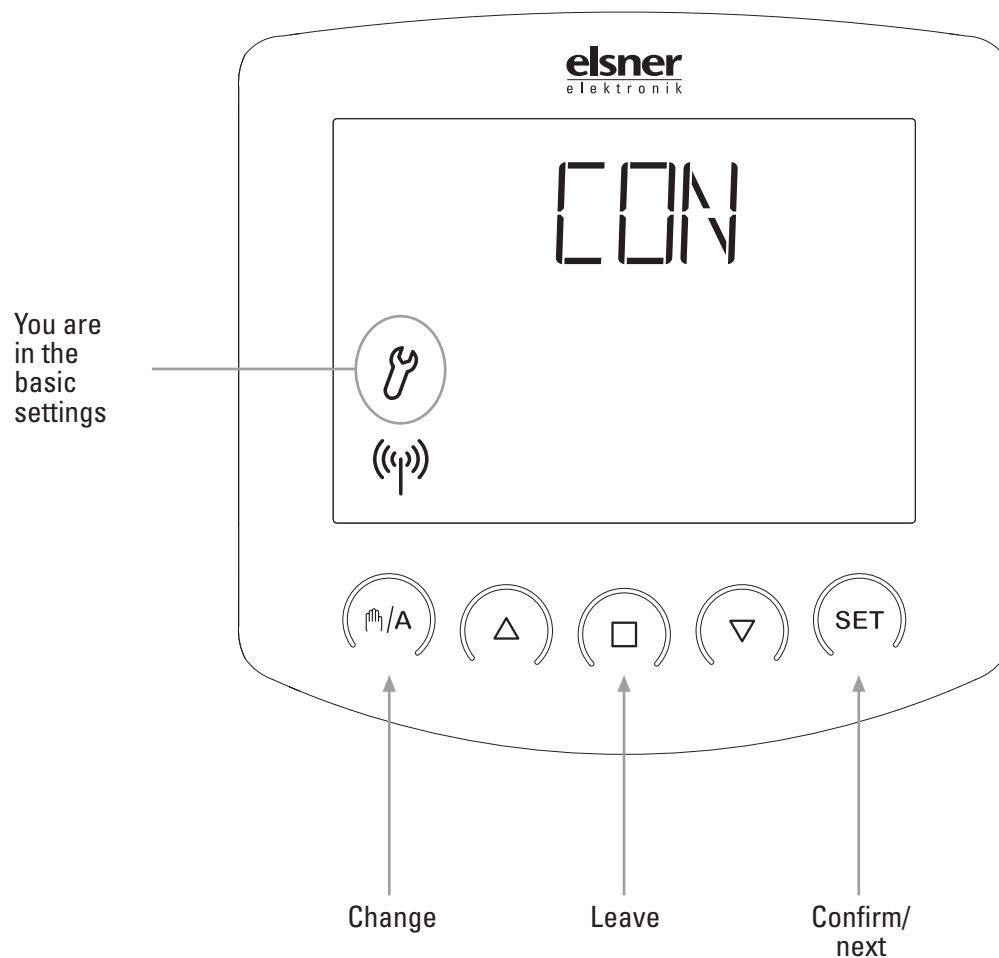

You may leave the basic settings at any time by pressing the key . The accomplished changes are not saved in this case.

If you do not press any key in the basic settings for 5 minutes, the display automatically changes to temperature display. Accomplished settings are not saved either.

1. Radio connection to the weather station

The first step is the teaching in (or later the deletion) of the radio connection.



Select the desired step with the /▲ key:

CON (continue) in order to skip this step,

LEA (learn) in order to teach in a radio connection to the weather station,

CLR (clear) in order to delete an existing radio connection.

Confirm your selection with the SET key.

As soon as you have confirmed LEA (learn) with the SET key, the radio symbol stops flashing and the radio waves are animated (they “run”). Now there are two possibilities:

1. Interrupt voltage supply¹:

Briefly interrupt the voltage supply of the weather station by switching off and on the fuse. The radio connection is learned immediately after switching on again.

2. Programming key of the weather station:

This option of the teaching in may only be accomplished by a qualified person for electronics.



Press the programming key inside the weather station in order to teach in the radio connection (you can find a diagram of the circuit board in the chapter "Preparation of the weather station").

The learning has been successful if the LED next to the programming key shortly flashes twice and the display skips to step 2 of the basic settings (rotational direction of the motor).

¹ from version 4.0 of weather station. Query of software version see "Query service data", p. 45.

As soon as you have confirmed CLR (clear) with the SET key, the radio connection is deleted. The display automatically skips to LEA (learn) in order to enable the teaching in of a new connection.

Delete all radio connections of the weather station

You can delete all radio connections of the weather station with operating units and hand-held transmitters at once by pressing the programming key for longer than 5 seconds. The programming LED will go on for 1 second for affirmation. Connections to motor control units are not deleted during this procedure.

2. Rotational direction of the motor

After the teaching in of the radio connection to the weather station, you may now set the rotational direction of the motor.



If the up and down connection cables have been mixed up when connecting the drive mechanism, this may be corrected in this step. First extend the shading a little bit for the rotational direction test. Check both arrow keys and make a setting in the display, whether the shading retracts (i.e. opens) with ∇ or with Δ .

If the shading opens (OPN, open) with key ∇ , then select the display $\square\square$ (down) with the key $\text{⏏}/\text{A}$.

If the shading opens (OPN, open) with key Δ , then select the display $\square\square$ (up) with the key $\text{⏏}/\text{A}$.

Press the SET key in order to access the next setting step.

ATTENTION!

Rain and wind alarm are deactivated for this test. Please observe not to damage the shading by moisture or wind.



3. Operating direction

After the setting of the rotational direction of the motor, now select whether the shading extends from top to bottom or from bottom to top.

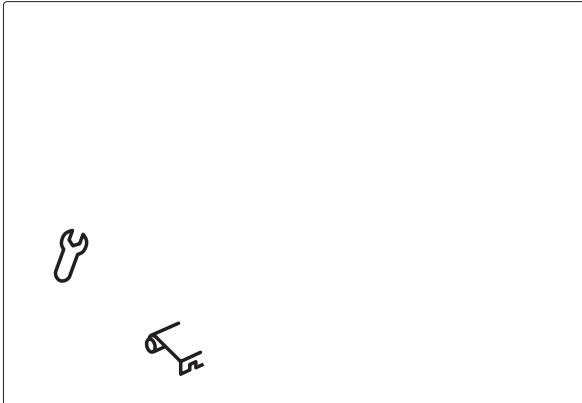

Depending on the model, shadings may extend from top to bottom or from bottom to top. In this step, you change the allocation of the arrow keys so that they correspond with the operating direction of the shading. You may directly test the setting with the arrow keys.

Press the key /▲ in order to switch between the displayed symbols. Select



if the awning or blind extends from top down
(the key ▽ extends the shading) or



if the awning or blind extends bottom-up.
(the key ▲ extends the shading).

Press the SET key in order to access the next setting step.

ATTENTION!

Rain and wind alarm are deactivated for this test. Please observe not to damage the shading by moisture or wind.



4. Operating command in case of wind or rain alarm

After the setting of the operating direction, you may now select whether the operating command in case of wind or rain alarm is temporary or permanent.





After the wind or rain alarm has been activated, the shading is retracted. The operating command for the connected drive mechanism either ends after 4 minutes or is permanently maintained as long as the alarm message exists.

The permanent operating command is necessary if Solexa is used as control centre for wired motor drive units (e. g. IMMSG 230) which control several drive mechanisms or when combined with a Lixa patio roof control.

Press the key /▲ in order to switch between the displays Off and On.

Select

 if in case of alarm, the operating command shall stop after 4 minutes (setting for conventional awning or blind control systems) or

 if in case of alarm, the operating command shall be permanently activated (operating command ends as soon there is no alarm message anymore).

Press the SET key in order to access the next setting step.

5. Sending of meteorological and automatic data

After the setting of the operating command in case of wind or rain alarm, you may now select, whether the meteorological data and the automatic commands of Solexa shall be submitted by radio to the motor control units of system XS.



Leave this display at **OFF** if Solexa is used as conventional single-channel control system. The function „Sending of weather and automatic data“ must only be activated if Solexa shall cooperate with motor control devices (e.g. XS MSG2-AP) in the control system XS.

Press the key /▲ in order to switch between the displays Off and On.

Select

OFF if no meteorological data and automatic commands shall be sent (setting for conventional awning or blind control) or

ON if the meteorological data and the automatic commands of the Solexa shall be sent to motor control devices of system XS (setting for the use in the control system XS).

This setting offers the option to centrally operate all drive mechanisms in system XS from the Solexa operating unit (see chapter “Manual operation”).

Press the SET key in order to access the next setting step.

6. Shading position

After the setting of the sending of meteorological and automatic data, you may now teach in a shading position.

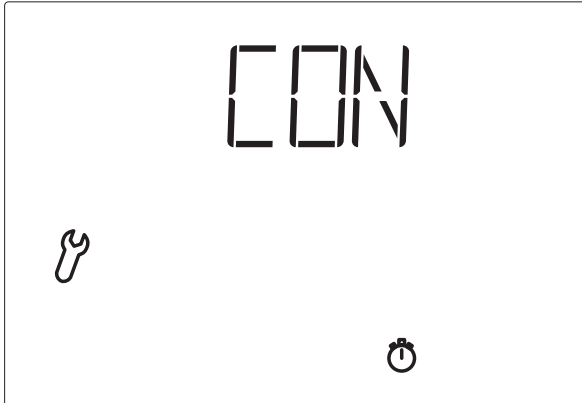

You may determine an individual position for awnings or blinds up to which the shading is extended in automatic mode. In case of blinds with slats, an additional aperture angle of the slats may be determined (reversing).

Select the desired step with the F_3/A key:

- `CON` (continue) in order to skip the setting of the shading position. The shading is then always completely extended by the automatic (closed). In this case, continue as described in chapter „7. Saving basic settings”.
- `LEA` (learn) in order to teach in the shading position.
- `CLR` (clear) in order to delete an already taught in shading position. The shading is then always completely extended by the automatic (closed). In this case, continue as described in chapter „7. Saving basic settings”.

Confirm your selection with the SET key.

Note: After switching from manual to automatic mode, the drive remains in the position set manually.

If the conditions for automatic shading *are not met*, the control retracts the hangings at the end of the retraction delay.

If the conditions for shading *are met*, the control at first retracts the hangings at the end of the extension delay (4-minute reference movement). After that the shading position is initiated.

6.1. Retracted position

After having confirmed `LEA` (learn), the command `OPN` (open) appears.

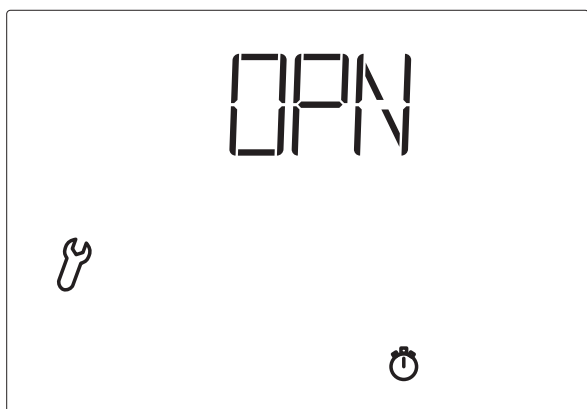

At first, completely retract the awning or blind so that there is no shading. Press the SET key in order to access the next setting step.

6.2. Setting of the desired position

The command `CLS` (close) appears.

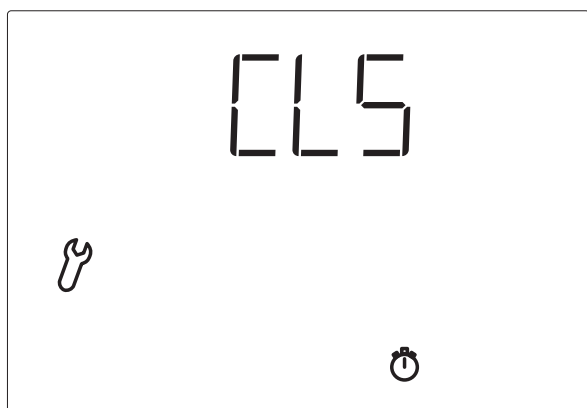

Now extend the shading as far as the automatic must extend it later in case of sunshine. Press the SET key in order to access the next setting step.

6.3. Slat angle

Command \overline{R} (reversing) appears.

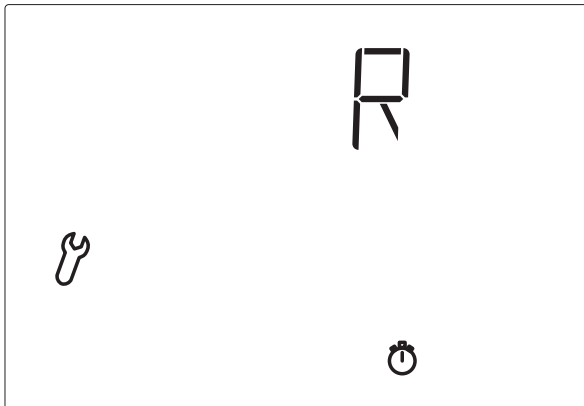

In case of blinds with slats, now open the slats in the desired angle. In case of awnings or if slats shall not be opened, do not move the shading. Then press the SET key in order to complete the setting of the shading position.

7. Saving of basic settings

At the end of basic settings, the symbol \overline{SAN} (save) asks whether the accomplished setting shall be saved.

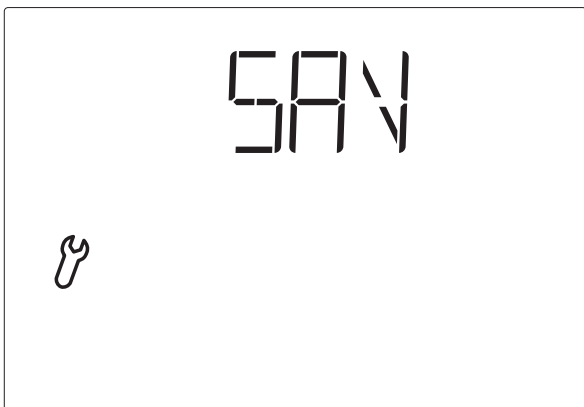

Press the SET key in order to save your entered data and to access the meteorological data display. With \square , you quit the basic settings without saving.

After the basic setting, the values for the automatic functions may be set. In case of first commissioning, please check the function of the sensors in advance (see chapter "Sensor testing").

Setting of automatic

For the awning or blind to shade optimally, the values for automatic operation must be adjusted to the local conditions. The following settings are queried one after the other:

- A. Lightness for the shading
- B. Extension delay
- C. Retraction delay
- D. Indoor temperature block
- E. Outdoor temperature block
- F. Wind alarm
- G. Rain alarm
- H. Storage

This is how you access the automatic settings:



In meteorological data display, press the SET key for at least 3 seconds in order to access the automatic setting.

You are in the automatic settings as soon as the symbols **A** and  are shown left in the display. You can see the first parameter (lightness) which must be set.

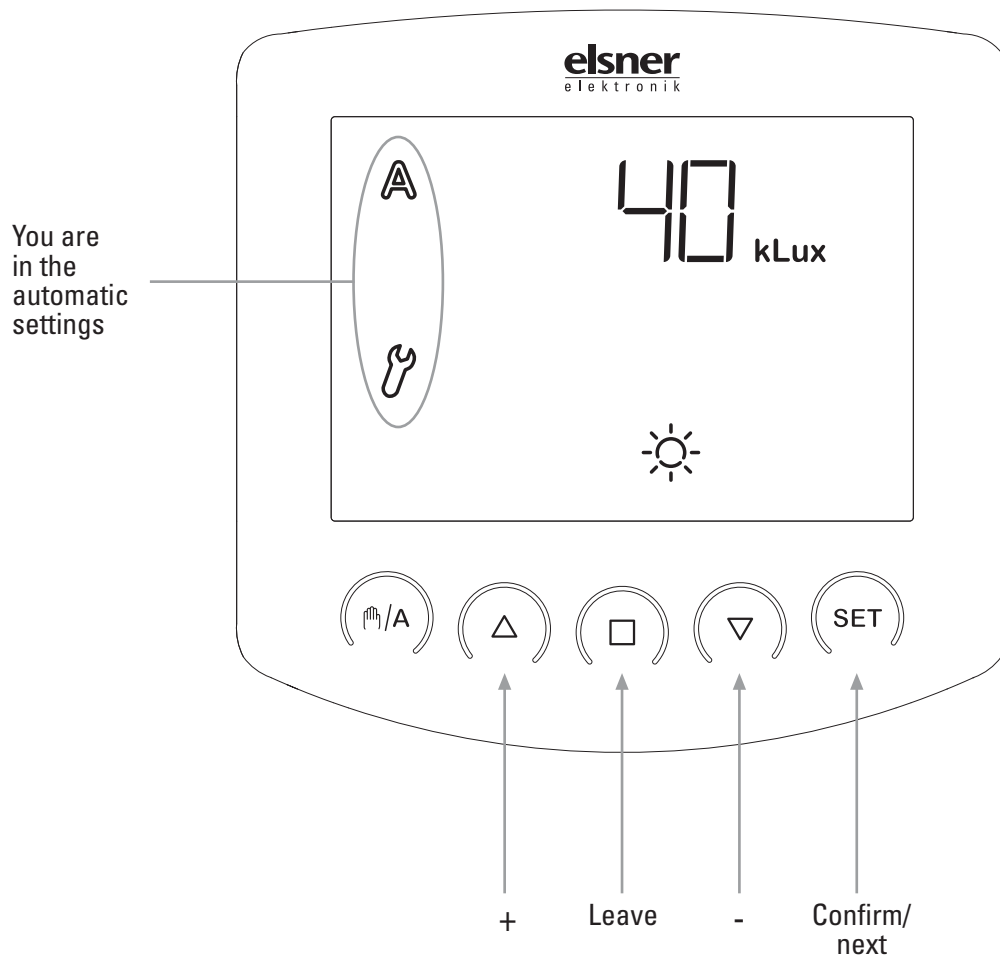

You may leave the automatic settings at any time by pressing the key . The accomplished changes of the values are not saved in this case.

If you do not press any key in the automatic settings for 5 minutes, the display automatically changes to temperature display. Accomplished settings are not saved either.

Safety instructions for automatic and alarm functions

WARNING!

Risk of injury due to automatically moved components!



The automatic control may cause parts of the system to travel and pose a danger to humans.

- No persons may remain in the travelling range of parts driven by an electric motor.
- Adhere to the relevant building regulations (see guideline for power-operated windows, doors and gates BGR 232 et al).
- Always disconnect the system from the mains power before maintenance or cleaning (e.g. switch off/remove fuse).

In case of power failure, drives and devices can no longer be controlled! If the complete scope of functions must be guaranteed in case of power fail, an emergency power generator with an according switch-over from mains operation to emergency operation must be installed.

Saved settings in the programme of the control also retain in case of power fail.

After the return of voltage, the control is in automatic mode.

If the radio connection between operating unit and weather station is interrupted (e.g. by radio interference or empty batteries in the operation unit), it is not possible anymore to take manual action. The control remains in the current mode (manual or automatic). The automatic mode continues as preset until there is radio connection again, however without considering the indoor temperature. In case of a preset manual mode, the wind and rain protection functions are retained as well.

If cleaning or maintenance work is to be carried out on the building, the system must be switched to neutral by switching off the installed fuse and be prevented from unintentional restart. Thus you ensure that the connected drive mechanisms do not start operation.

In case of beginning rain, a certain period of time, which depends on the amount of rain, may pass by until the weather station recognises that there is rain.

Please also take into account that e.g. in case of power fail and beginning rain, exterior awnings are not automatically retracted if there is no emergency power generator.

Please note that the rails of sun protection systems which are installed outdoor may ice over. If the awning or blind is then moved, shading and drive mechanism may be damaged.

A. Lightness for the shading

In the automatic settings, you must indicate at first the lightness from which shading shall start.



Sun intensity is displayed in kilolux (kLux). The value of 1 kLux is already reached in case of a cloudy sky, 20 kLux indicates that the sun has just come out and 100 kLux are achieved with blue sky at noon.

The presetting for lightness is 40 kLux.

Adjust the value with Δ (higher) and ∇ (lower) or select $\square\square\square$ (off) in order to switch off the function. You reach the setting $\square\square\square$ by pressing ∇ once more when the display shows "1 kLux". If you select $\square\square\square$, there is no control in terms of lightness. Therefore, the following automatic parameters (chapter B to E) are skipped. In this case, the shading may be operated manually and is protected from wind and rain (if the protection function has been activated, see chapter "F. Wind alarm" and "G. Rain alarm").

Press SET in order to get to the setting of the next parameter.

B. Extension delay

After the setting of the lightness, now enter the delay time for the extension of the shading.

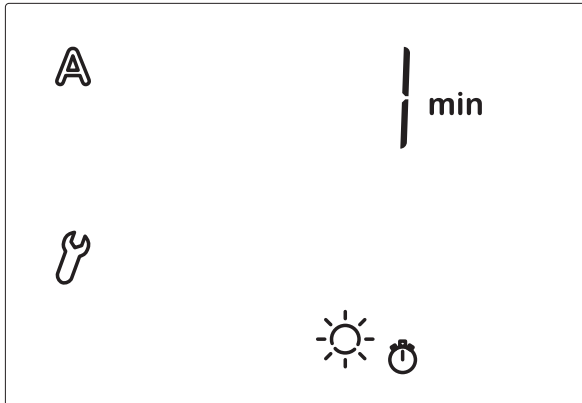

The purpose of the delay is that the shading does not permanently extend and retract in case of fast changing lightness conditions.

The presetting for the extension is 1 minute. Thus, for one minute, the lightness must be continuously higher than the value which you have set (topic A of the automatic settings) for the shading to extend. Thus, the shading quickly reacts to the sun. Adjust the value with Δ (higher) and ∇ (lower). Then press SET in order to access the setting of the next parameter.

C. Retraction delay

After the setting of the extension delay, now enter the delay time for the retraction of the shading.

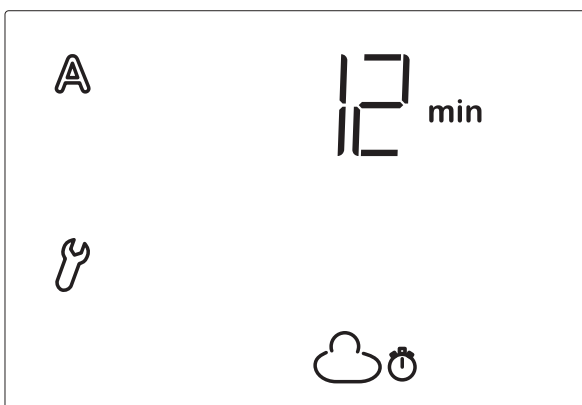

The presetting for the retraction is 12 minutes. Thus, for 12 minutes, the lightness must be continuously lower than the value which you have set (topic A of the automatic settings) for the extended shading to retract. Thus, clouds passing by are „ignored”.

Adjust the value with \triangle (higher) and ∇ (lower). Then press SET in order to access the setting of the next parameter.

D. Indoor temperature block

After the setting of the retraction delay, now select the indoor temperature below which shading shall be prevented.

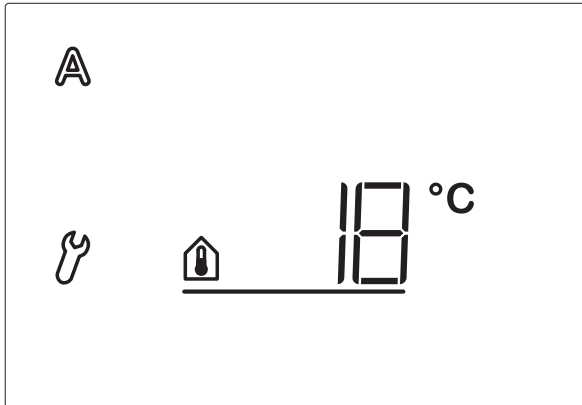

By means of the indoor temperature block, you may use the sun in order to obtain the desired room temperature (e.g. in winter). Only if the value is exceeded, the shading extends in case of sun. The indoor temperature is only applied for the automatic mode of the control system. The manual operation of the shading is still possible.

The hysteresis of the indoor temperature block is 3°C. That means, the shading is blocked only after the indoor temperature has dropped below the set value more than 3°C.

The presetting for the indoor temperature block is 18°C.

Adjust the value with \triangle (higher) and ∇ (lower) or select OFF (off) in order to switch off the indoor temperature block. You reach the setting OFF by pressing ∇ once more when the display shows "5°C".

Then press SET in order to access the setting of the next parameter.

E. Outdoor temperature block

After the setting of the indoor temperature block, now select the outdoor temperature below which shading shall be prevented.

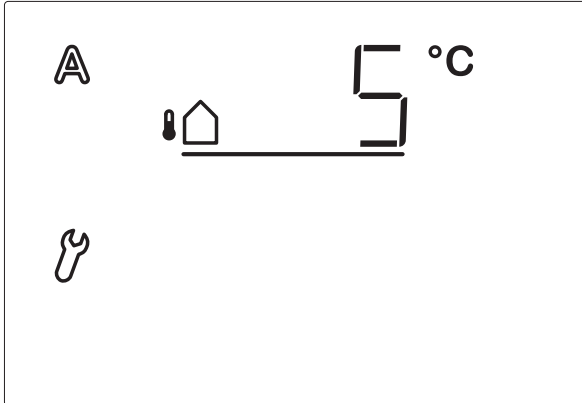

The outdoor temperature block is important for exterior sun protection systems. In case of frost, the awning or blind may freeze in the slide rails. If the shading is then moved, it may be damaged. Please note that the slide rails or other mechanical components may still be frozen although the outdoor temperature has considerably high values. Please enquire the blocking temperature for your shading at your winter garden manufacturer. The hysteresis of the outdoor temperature block is 2°C. That means, the shading is released only after the outdoor temperature has extended the set value more than 2°C.

If your shading also operates at low temperatures or if it is installed indoor, please deactivate the outdoor temperature block (display OFF).

ATTENTION!

Outdoor as well as indoor temperature blocks only apply for the automatic mode. Manual operation is further possible. Therefore, please observe possible icings if you open and close manually.



The presetting for the outdoor temperature block is 5°C.

Adjust the value with \triangle (higher) and ∇ (lower) or select OFF (off) in order to switch off the outdoor temperature block. You reach the setting OFF by pressing ∇ once more when the display shows “-20°C”.

Then press SET in order to access the setting of the next parameter.

F. Wind alarm

After the setting of the outdoor temperature, now provide the value for the wind protection function.

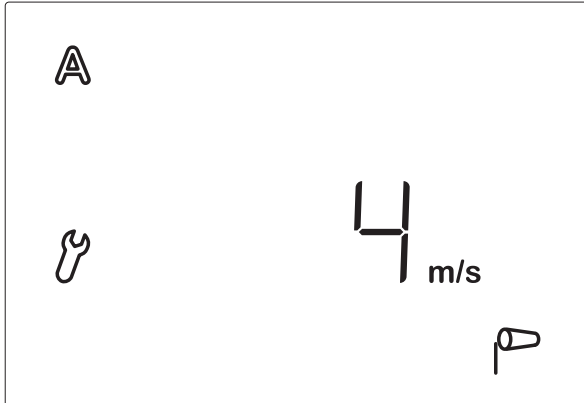

The wind alarm protects the exterior shadings from damage. If the indicated wind value is exceeded, the awning or blind is retracted and manual operation is blocked. Wind speed is indicated in m/sec (meters per second). The wind alarm is maintained for 5 minutes. If the set wind value is exceeded within these 5 minutes, the stop time starts from the beginning.

The following table (see next chapter) serves as indication in order to set the wind value. Depending on the position of the winter garden and the assembly position of the weather station, different wind values may be optimal for the protection of the shading. Observe the behaviour of the awning or blind in case of wind and correct the wind value accordingly.

The presetting for the retraction in case of wind is 4 m/sec.

Adjust the value with \triangle (higher) and ∇ (lower) or select OFF (off) in order to deactivate the function. Then press SET in order to access the setting of the next parameter.

Table for wind speeds

Description	m/sec	km/h	Beaufort	knots
Calm	< 0,3	< 1,1	0	< 1
Almost calm	0,3-1,5	1,1-5,4	1	1-3
Very weak wind	1,6-3,3	5,5-11,9	2	4-6
Weak wind	3,4-5,4	12,0-19,4	3	7-10
Moderate wind	5,5-7,9	19,5-28,4	4	11-16
Fresh wind	8,0-10,7	28,5-38,5	5	17-21
Very fresh wind	10,8-13,8	38,6-49,7	6	22-27
Strong wind	13,9-17,1	49,8-61,5	7	28-33
Very strong wind	17,2-20,7	61,6-74,5	8	34-40
Storm	20,8-24,4	74,6-87,8	9	41-47
Heavy storm	24,5-28,4	87,9-102,2	10	48-55
Gale-force wind	28,5-32,6	102,3-117,3	11	56-63
Hurricane	> 32,6	> 117,3	12	> 63

G. Rain alarm

After the setting of the wind alarm, now select whether the rain alarm shall be switched on or off.

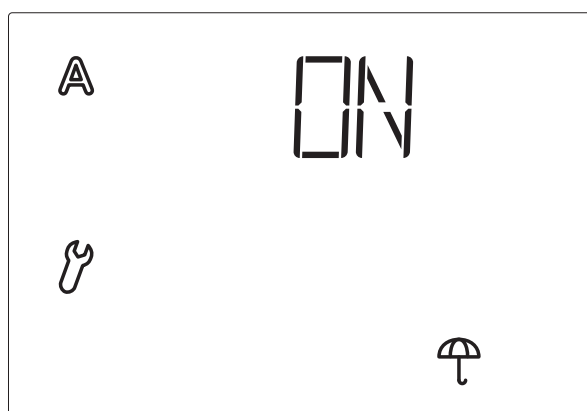

The rain alarm protects the exterior shadings, particularly awning fabric, from damage. In case of rain alarm, the shading is automatically retracted and manual operation is blocked.

The rain message is maintained for 5 minutes. If the system recognises rain again during these 5 minutes, the stop time starts from the beginning.

In the presetting, the rain alarm is activated (display **ON**). With the arrow keys, you may select between activated (display **ON**) and deactivated (display **OFF**). Then press SET in order to get to the storage of the setting.

H. Storage of automatic settings

At the end of the entry of automatic settings, the symbol  (save) asks whether the accomplished setting shall be saved.



Press the SET key in order to save your entered data and to access the meteorological data display. With , you quit the automatic settings without saving.

Service

Service and maintenance

Weather station

WARNING!

Risk of injury caused by components moved automatically!

The automatic control can start system components and place people in danger.

- Always isolate the system from the mains for servicing and cleaning.



The device must regularly be checked for dirt twice a year and cleaned if necessary. In case of severe dirt, the sensor may not work properly anymore.

In case of power fail, the entered data will be stored for approx. 10 years. Batteries are not necessary for this purpose.

ATTENTION

The device can be damaged if water penetrates the housing.

- Do not clean with high pressure cleaners or steam jets.



Operating unit

Clean the display with a wet cloth, if necessary.

Insert batteries (operating unit)

The battery compartment is inside the housing.

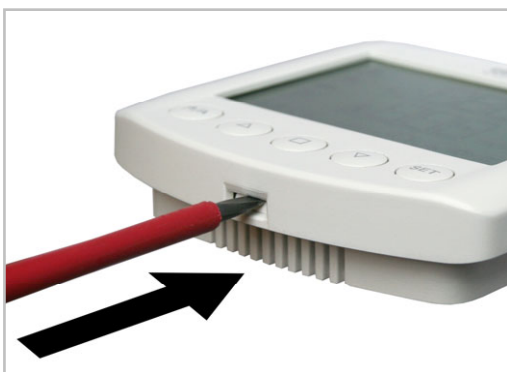

Open the operating unit by unlocking the locking at the lower rim of the housing. For this purpose, you must press with a screwdriver straight into the gap.

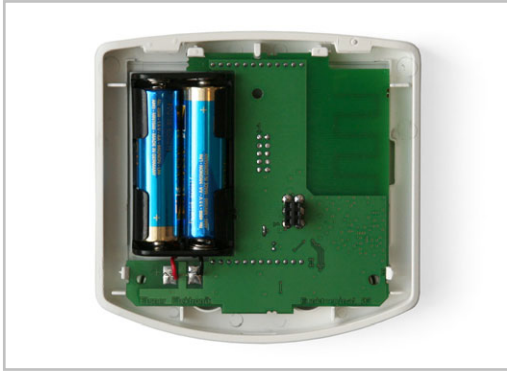

Observe the correct polarity of the batteries. You need two standard batteries (1.5 V) or accumulators (1.2 V) of type AA (Mignon/ LR6).

Close the housing by fitting the front panel with circuit board from above into the rear panel. The locking must engage with a clearly noticeable “click”.

Error messages

Despite the values for temperature, lightness or wind speed, the display may indicate error messages in the meteorological data display.

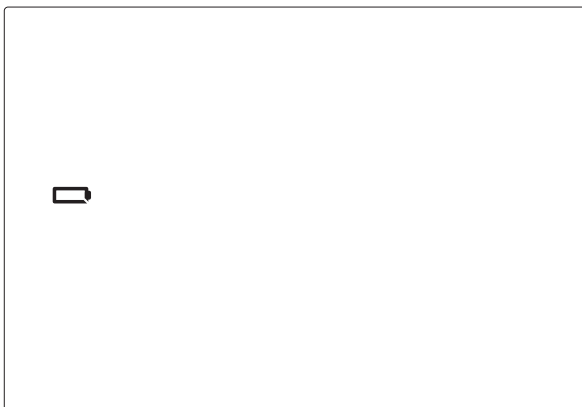

Error:

Battery is displayed, no other symbols or values. Manual operation is possible.

Cause: Batteries in the operating unit are empty and must be changed. Attention: The function of the operating unit may not be guaranteed anymore.

Action: Change batteries as described in chapter “Insert batteries”.

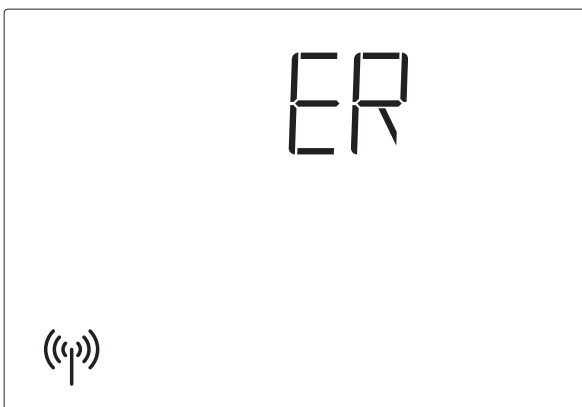

Error:

ER and the symbol for radio appear in the display.

Cause: No radio connection between operating unit and weather station. The weather station is out of order (e.g. has no voltage) or the radio connection is interrupted or has not yet been taught in.

Action:

The error may only be corrected by a qualified person for electronics. Therefore, please contact your fitter.



The teaching in of the radio connection between weather station and operating unit is described in chapter “1. Radio connection to weather station”.

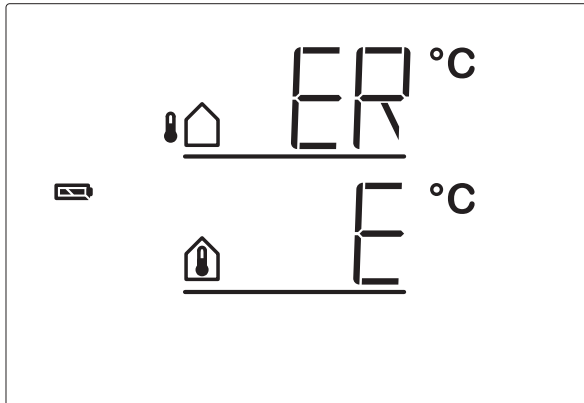

Error:

ER instead of outdoor temperature or
E instead of indoor temperature

Cause: The outdoor temperature sensor of the weather station or the indoor temperature in the operating unit is defect.

Action:

The error may only be corrected by a qualified person for electronics. Therefore, please contact your fitter.

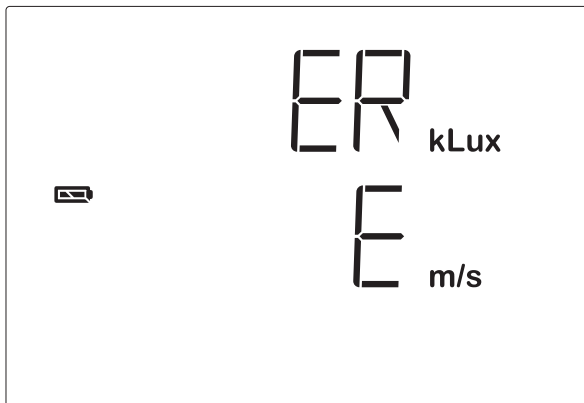

Error:

ER instead of lightness or
E instead of wind speed

Cause: Lightness sensor or wind sensor of the weather station are defect.

Action:

The error may only be corrected by a qualified person for electronics. Therefore, please contact your fitter.



Query service data

The software version of the operating unit and the weather station may be indicated in the display. From the basic settings you may get to the service menu by a long pressing of SET (3 seconds). At first, the software version of the operating unit (PAN,

panel) is indicated, after the short pressing of SET, the software version of the control/weather station (EOL, Solexa) is indicated. Display 10 means version 1.0, 12 means 1.2, etc. Quit the service data display by another short pressing of SET.

Disposal

The device must not be disposed of with domestic waste and therefore is labelled with the "crossed-out dustbin" icon.

End users are statutorily required by s. 18 Battery Act to return old batteries. After use, the batteries can be returned to Elsner Elektronik free of charge or they can be recycled via a public-law waste management provider.

Factory settings

The following presetting for the automatic is stored when the Solexa control system is delivered:

- Shading beginning with a sun intensity of > 40 kLux
- Delay time in case of sunshine until shadings extend: 1 min, retract: 12 min
- Blocking until indoor temperature > 18°C
- Blocking until outdoor temperature > 5°C
- Wind alarm beginning with 4 m/sec
- Rain alarm activated

Abbreviations

kLux: Kilolux (= 1000 Lux), unit of light intensity.
m/s: Metres per second, unit of wind strength

Technical data

The product conforms with the provisions of EU directives.

Operating unit

Housing:	Plastic material (partly lacquered)
Colours:	<ul style="list-style-type: none">• White matt (similar to RAL 9016 Traffic White)• Aluminium matt brush finished• Pearl dark grey matt brush finished
Mounting:	On-wall
Degree of protection:	IP 20
Dimensions:	approx. 103 × 98 × 28 (W × H × D, mm)
Total weight:	approx. 170 g (including batteries)

Ambient temperature:	Operation 0...+50 °C, Storage -10...+50 °C
Ambient air humidity:	5...80 % RH, avoid bedewing
Operating voltage:	2 x 1.5 V (2 batteries, AA/Mignon/LR6) or 2 x 1.2 V (2 rechargeable batteries, AA/Mignon/LR6)
Radio frequency:	868.2 MHz
Direction change pause:	1 s
Measurement range temperature:	0...+50°C

Weather station

Housing:	Plastic material
Colour:	White / translucent
Mounting:	On-wall
Degree of protection:	IP 44
Dimensions:	approx. 96 × 77 × 118 (W × H × D, mm)
Weight:	approx. 260 g
Ambient temperature:	Operation -30...+60 °C, Storage -30...+70 °C
Operating voltage:	230 V AC, 50 Hz
Power consumption:	Stand by: approx. 3.5 W / 230 V Operation: approx. 4 W / 230 V
Output:	1 x Drive mechanism (up/down/N/PE), can carry up to 1000 W, fused with micro fuse T 6.3 A
Heating rain sensor:	approx. 1.2 W
Measurement range temperature:	-40...+80 °C
Measurement range wind:	0...35 m/s
Measurement range brightness:	0...150 klux

Connection diagram for weather station

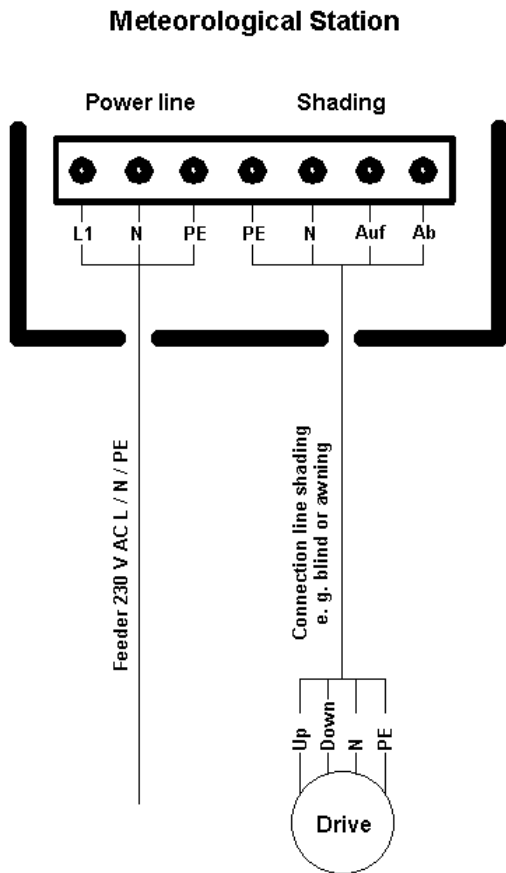

The operating unit is battery-powered. Operating unit and weather station communicate via radio.

Connection samples for several drive mechanisms as group

Connection examples for several drives

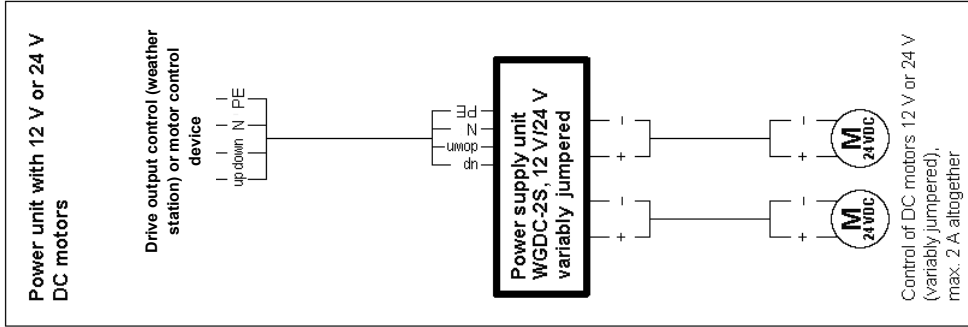
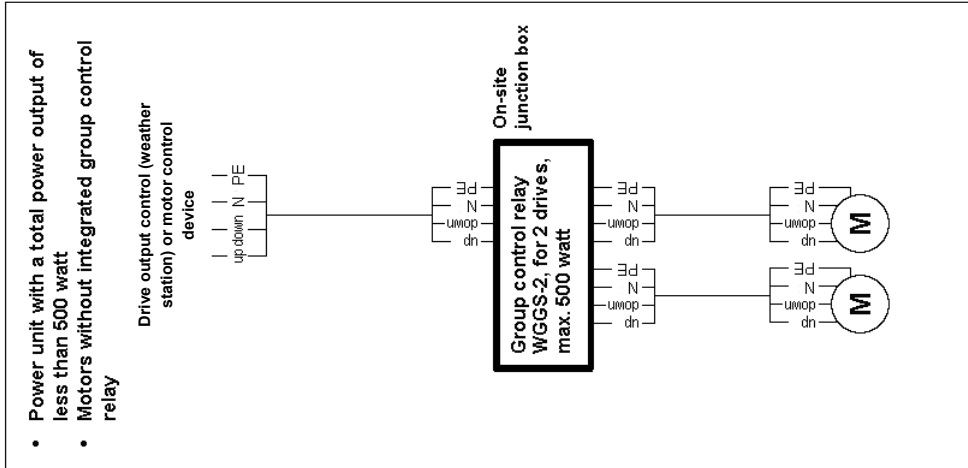
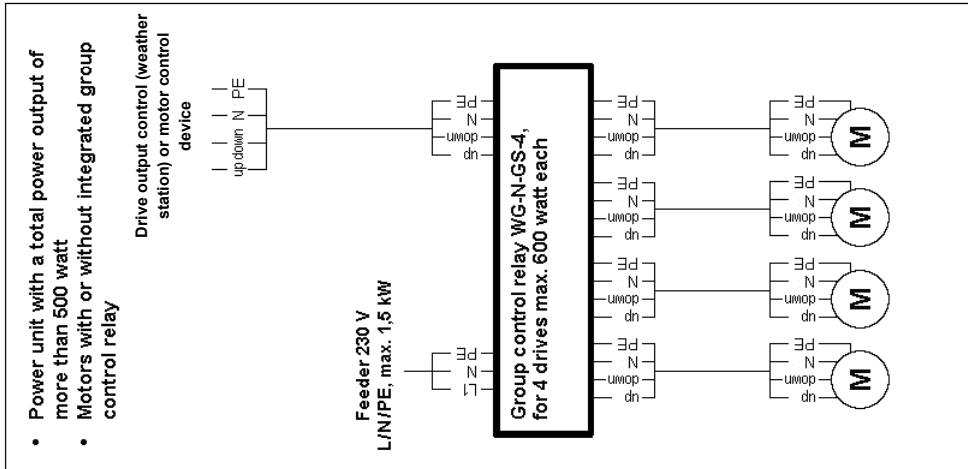
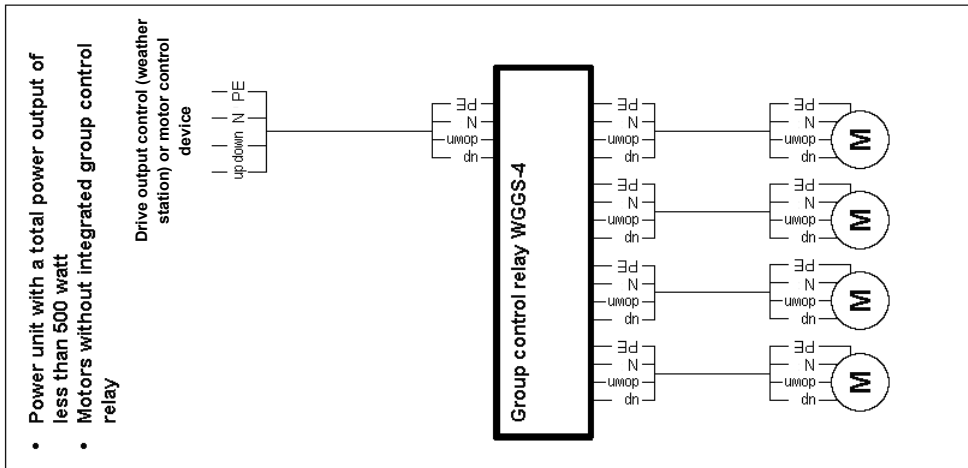

Connection samples for centralised control with IMMSG 230 compact

Simple central control with motor control units at the drive output of Solexa weather station:

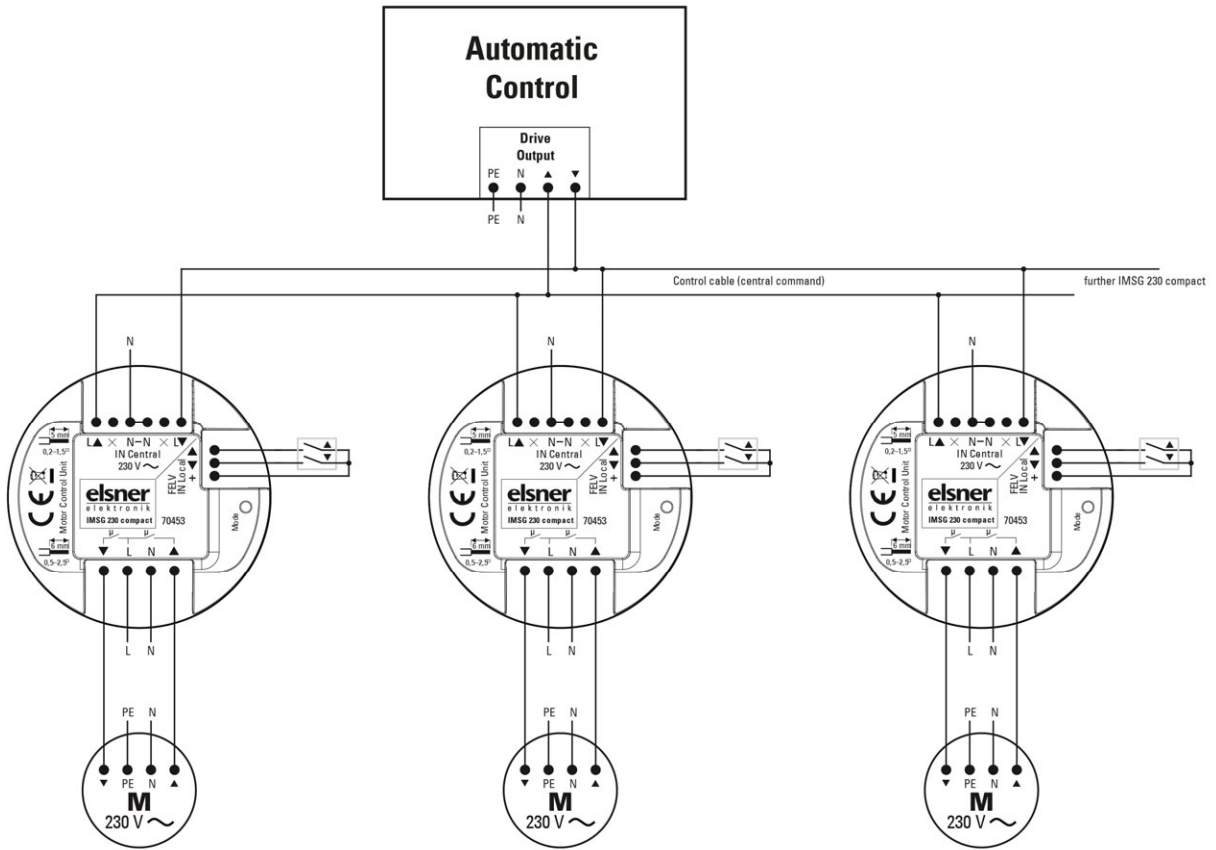

Central control with group formation with motor control units at the drive output of Solexa weather station:

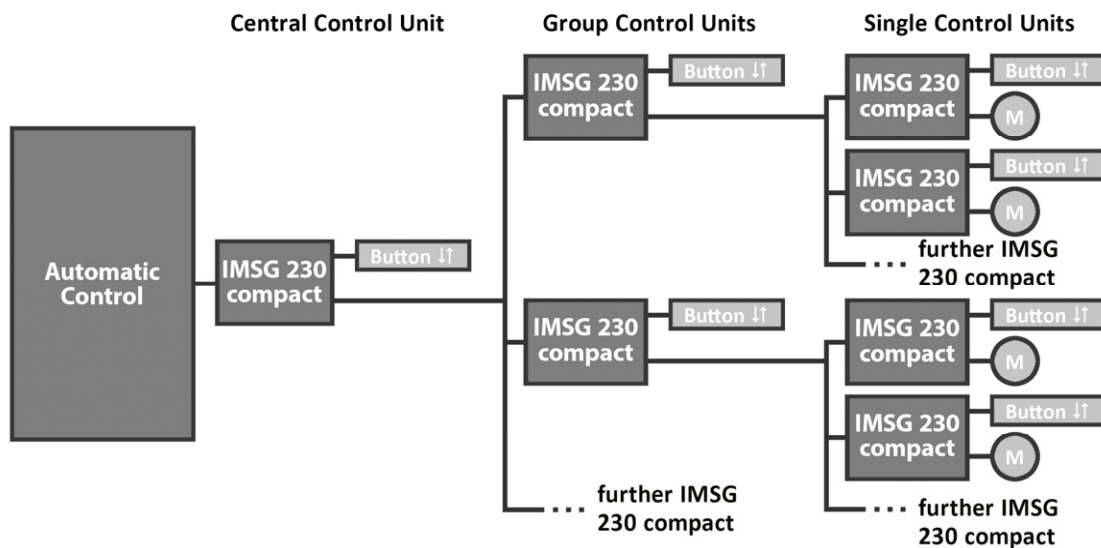

Personal setting data of the automatic

Shading if lightness exceeds		kLux
Delay time of extension		min
Delay time of retraction		min
Shading if indoor temperature exceeds		°C
Outdoor temperature block below		°C
Wind alarm from		m/sec
Rain alarm		(Yes/No)

Questions about the product?

You can reach the technical service of Elsner Elektronik under
Tel. +49 (0) 70 33 / 30 945-250 or
service@elsner-elektronik.de

We need the following information to process your service request:

- Type of appliance (model name or item number)
- Description of the problem
- Serial number or software version
- Source of supply (dealer/installer who bought the device from Elsner Elektronik)

elsner

Elsner Elektronik GmbH Control and Automation Technology

Sohlegrund 16
75395 Ostelsheim
Germany

Phone +49(0)7033/30945-0

Fax +49(0)7033/30945-20

info@elsner-elektronik.de

www.elsner-elektronik.de
