

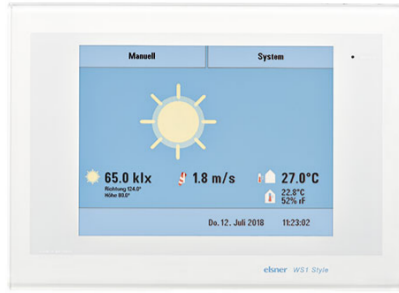

Brief Instruction Mounting of WS1 Style

Item numbers 60180-60189 (WS1 Style), 60194 (WS1 Style-4 PF)



The manual with additional information about commissioning, functions and use of the controls **WS1 Style** can be downloaded from www.elsner-elektronik.de in the menu area "Service/Downloads".

 **Warning, mains voltage! National legal regulations are to be observed. Installation, inspection, commissioning and troubleshooting of the device must only be carried out by a competent electrician.**

Notes on wireless equipment

When planning facilities with devices that communicate via radio, adequate radio reception must be guaranteed. The range will be limited by legal regulation and structural circumstances. Avoid sources of interference and obstacles between receiver and transmitter, that could disturb the wireless communication. Those would be for example:

- Walls and ceilings (especially concrete and solar protection glazing).
- Metal surfaces next to the wireless participants (e. g. aluminium construction of a conservatory).
- Other wireless devices and powerful local transmitters (e.g. wireless headphones), which transmit on the same frequency. Please maintain a minimum distance of 30 cm between wireless transmitters for that reason.

Preparing the installation location

 **The device must only be installed and used in dry, interior spaces. Avoid condensation.**

The device is to be installed flush to the wall surface. When selecting an installation location, please ensure that the measurement results of the integrated temperature/humidity sensor are affected as little as possible by external influences. Possible sources of interference include:

- Direct sunlight
- Drafts from windows and doors
- Draft from ducts which lead from other rooms to the concealed box
- Warming or cooling of the building structure on which the device is mounted, e.g. due to sunlight, heating or cold water pipes
- Connection lines which lead from warmer or colder areas to the device

Cut-out dimensions for concealed box:

W = 166 mm +1 -0 | H = 116 mm +1 -0 | D = 80 mm

An external antenna can be connected in order to improve wireless communications. During installation, a **conduit 50 cm in length** should be placed beneath the recessed housing, in which the external antenna can be mounted (antenna dimensions approx. 565 x 8 x 5, L x W x H in mm):

Conduit angled diagonally downwards (for cable access from above or below)

Conduit angled vertically downwards (only for cable access from above!)

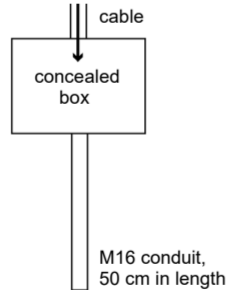
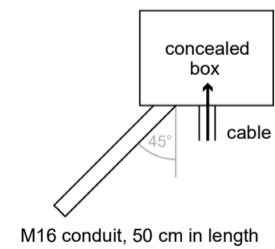

Preparing for installation



The display unit is held by magnets. Remove the front part from the concealed box.

Caution: The display is connected with a flat-ribbon cable to the circuit board in the concealed box.

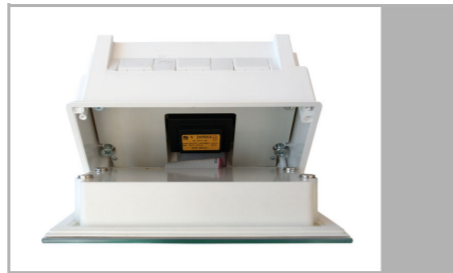

Loosen the plug so that the display unit can be removed.

Remove all parts of the transportation lock/packing.

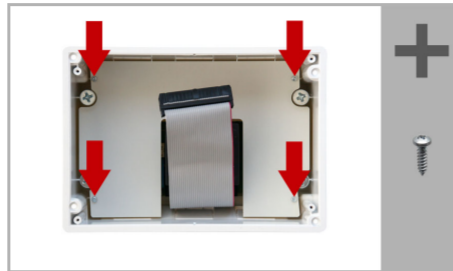

The security covering in the concealed box is attached with four screws: Loosen the screws and take off the security covering.

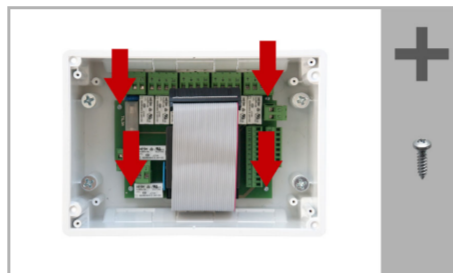

Remove the circuit board from the concealed box to be installed a keep it in a place where it is protected from dirt. **It may never be exposed to dust or moisture!**

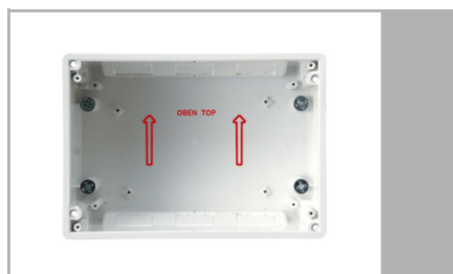

Place the concealed box in the wall so that the arrows point upwards.

Wall-fitting



For fitting, screw the cover (board) on to the concealed box with the enclosed screws.

Cavity wall fitting



Clamp the concealed box to the wall with the four enclosed screws.

Upon delivery, the pouch containing the assembly screws can be found in the control unit's concealed box.

Assembling the control unit with concealed box

During electrical installation, please introduce all connection cables into the concealed box through the lower or upper side wall. In the process, keep the individual connection wires short to prevent long reserve loops.

After connecting the cables screw the security covering onto the concealed box.

 **The security covering must be fixed before the control is put into operation! It prevents contact with current-carrying parts in the concealed box.**

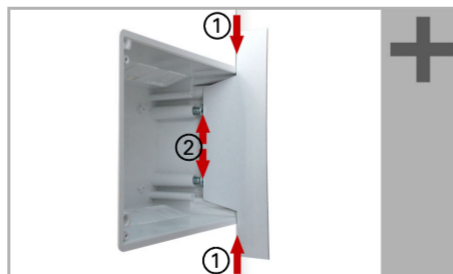

Adjust the screws of the magnetic mounting with the enclosed template. Each of the four screws must be adjusted individually in height.

When the edge of the template rests on the wall surface (1), the template must rest on the mounting screws as well (2).

By adjusting the mounting screws, the display unit will rest flat on the wall later and be held by the magnets safely.

Connect the flat ribbon cable to the display and place the display unit on the concealed box. The magnets must be attracted by the mounting screws considerably and the display unit must rest tightly on the concealed box.

Structure of the connector board WS1 Style

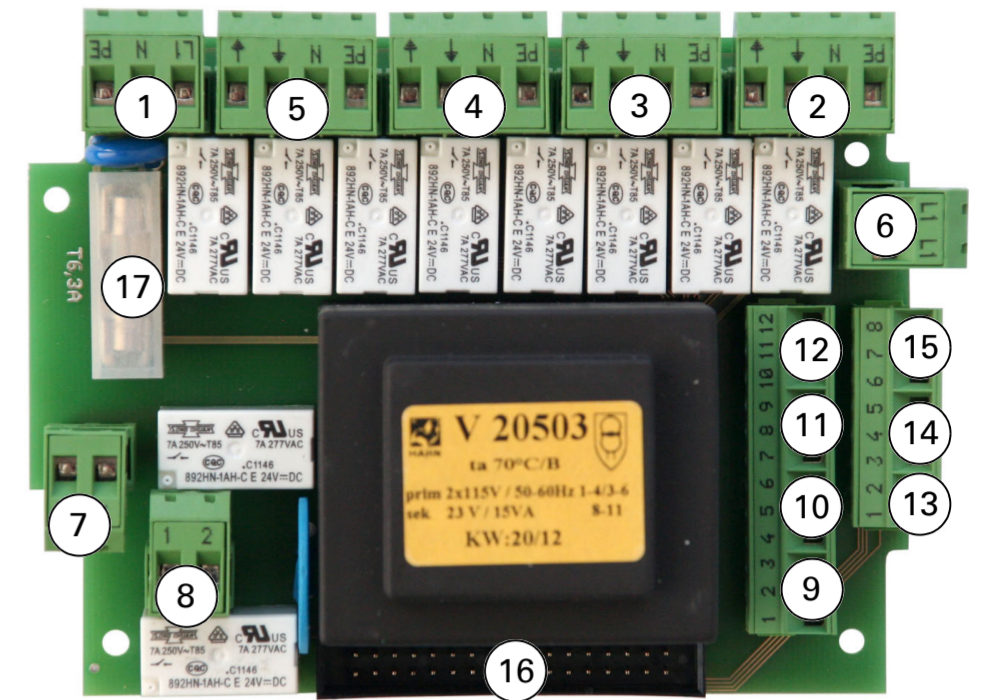

- | | |
|--|--|
| 1 Mains connection
L/N/PE 230 V/50 Hz | 12 Wall button 4
(10: +12V 11: Up 12: Down) |
| 2 Drive group 1 | 13 Weather station (terminals 1-2)
Wire assignment: red = 1, black = 2,
yellow and white = not connected |
| 3 Drive group 2 | 14* Multifunctional input 1
(terminal 3: +12 V 4: GND 5: IN) |
| 4 Drive group 3 | 15* MF input 2 (6: +12 V 7: GND 8: IN) |
| 5 Drive group 4 | 16 Connector for flat-ribbon cable to
front board |
| 6 Outer conductor L1 | 17 Microfuse T6,3 A |
| 7 Multifunctional output 1
(potential-free) | |
| 8 MF output 2 (potential-free) | |
| 9 Wall button 1
(terminal 1: +12 V 2: Up 3: Down) | |
| 10 Wall button 2
(4: +12 V 5: Up 6: Down) | |
| 11 Wall button 3
(7: +12 V 8: Up 9: Down) | |

* Supply voltage e. g. indoor sensor possible via MF inputs (No. 14, terminal 3(+), 4(-) and No. 15, terminal 6(+), 7(-)), max. 50 mA altogether.

Structure of the connector board WS1 Style-PF

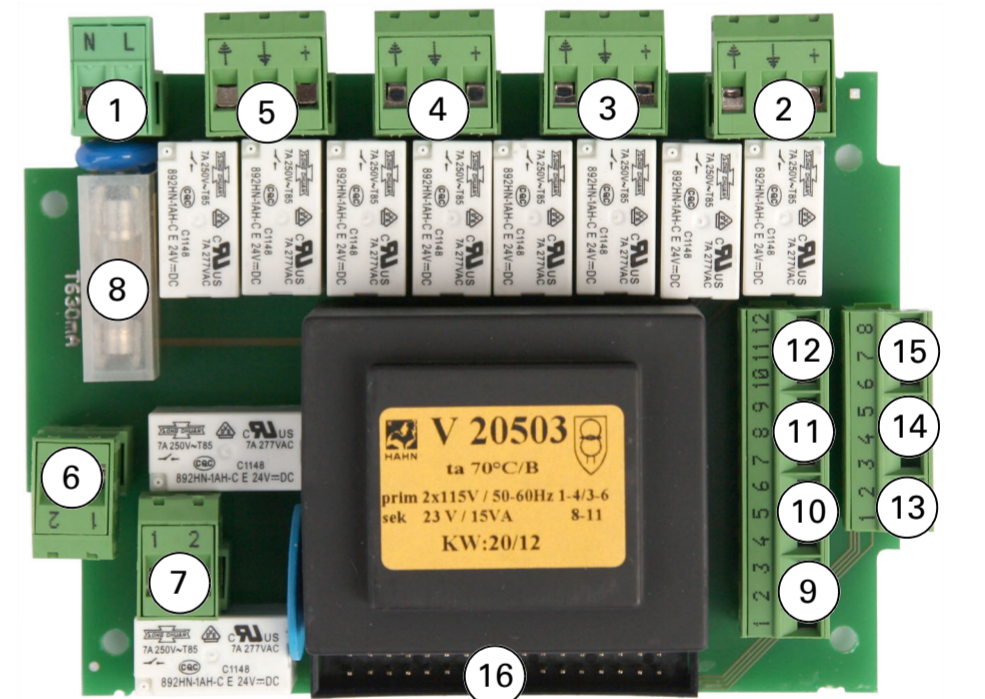

- | | |
|--|--|
| 1 Mains connection
L/N/PE 230 V/50 Hz | 12 Wall button 4
(10: +12V 11: Up 12: Down) |
| 2 Drive group 1 | 13 Weather station (terminals 1-2)
Wire assignment: red = 1, black = 2,
yellow and white = not connected |
| 3 Drive group 2 | 14* Multifunctional input 1
(terminal 3: +12 V 4: GND 5: IN) |
| 4 Drive group 3 | 15* MF input 2 (6: +12 V 7: GND 8: IN) |
| 5 Drive group 4 | 16 Connector for flat-ribbon cable to
front board |
| 6 Multifunctional output 1
(potential-free) | |
| 7 MF output 2 (potential-free) | |
| 8 Microfuse T630 mA | |
| 9 Wall button 1
(terminal 1: +12 V 2: Up 3: Down) | |
| 10 Wall button 2
(4: +12 V 5: Up 6: Down) | |
| 11 Wall button 3
(7: +12 V 8: Up 9: Down) | |

* Supply voltage e. g. indoor sensor possible via MF inputs (No. 14, terminal 3(+), 4(-) and No. 15, terminal 6(+), 7(-)), max. 50 mA altogether.

Connection diagrams

Drive and MF outputs WS1 Style (60180-60189):

max. 400 W per motor output,
total max. 1.5 kW for all motor outputs

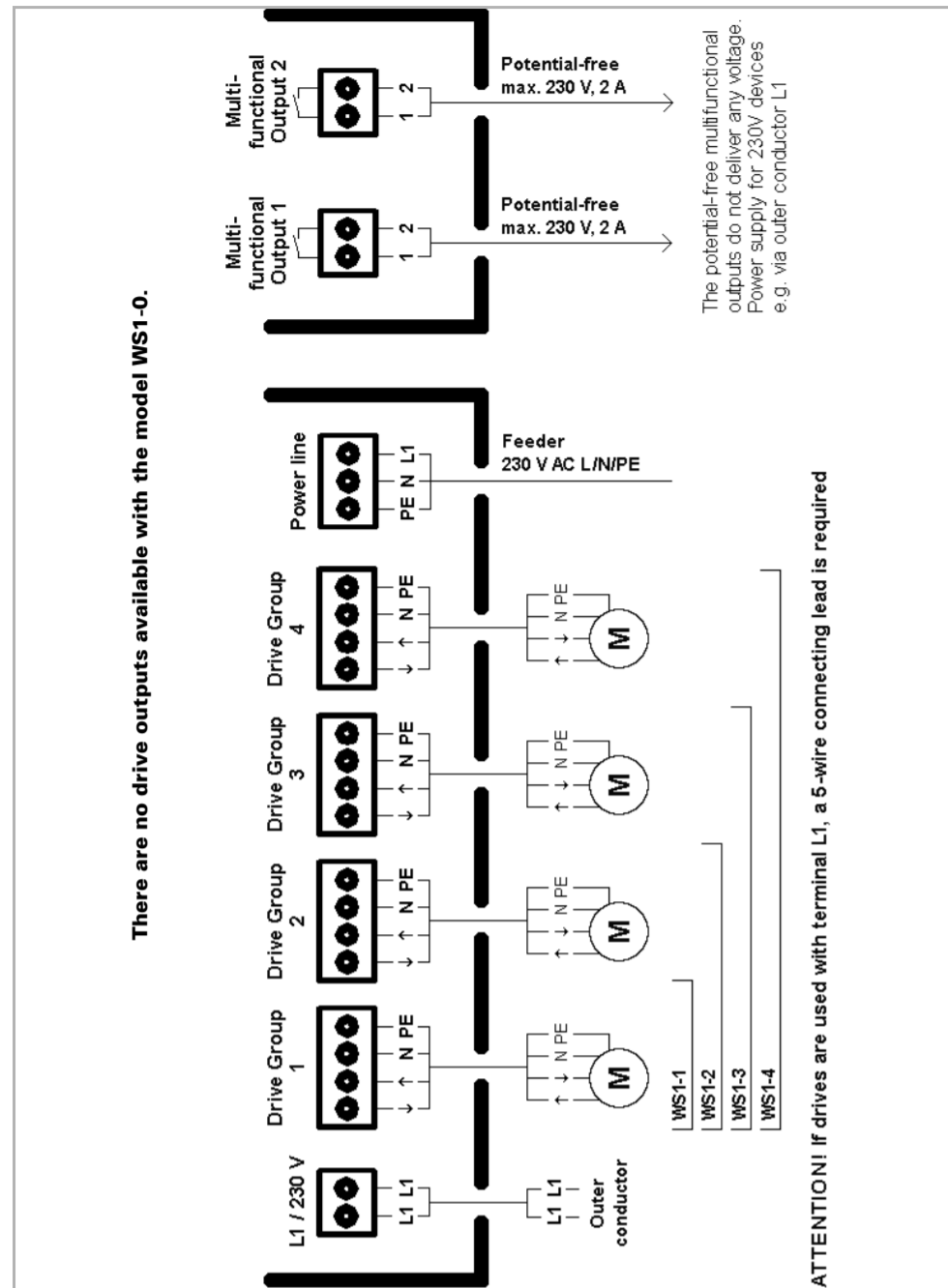

Drive and MF outputs WS1 Style-PF (60194):

per motor output max. 5 A / 230 V

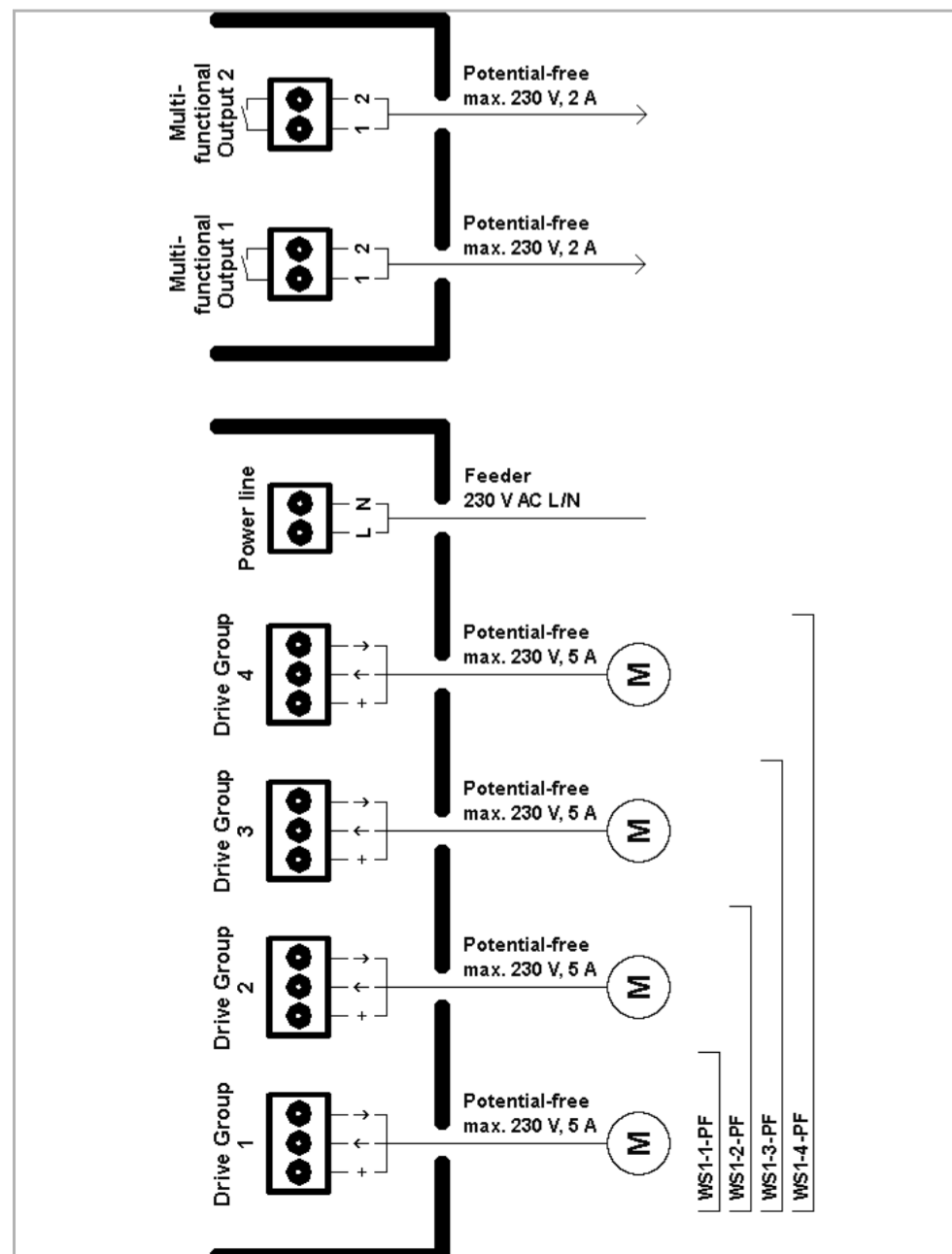

Inputs WS1:

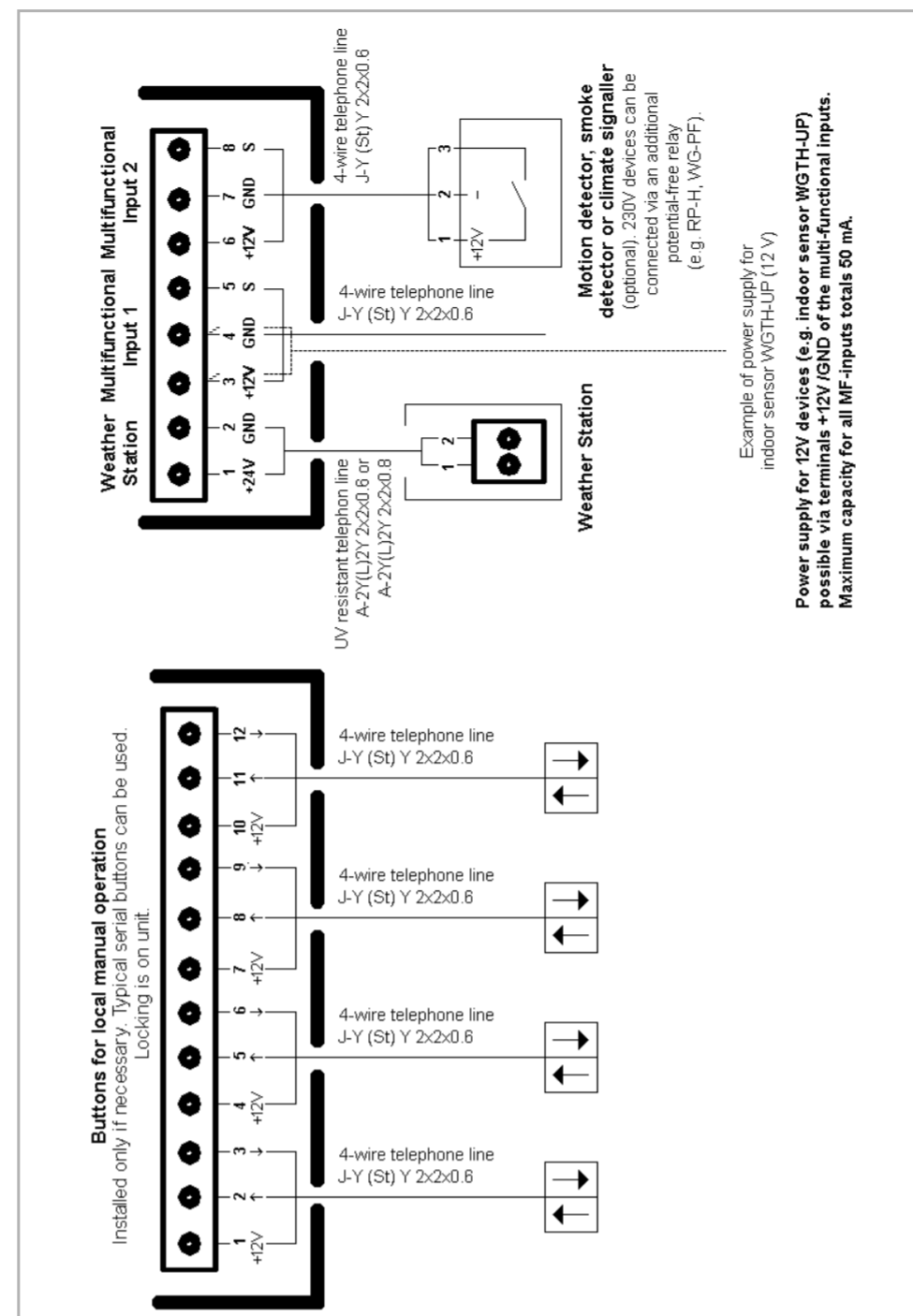

Connection examples for multifunctional outputs

Connecting 230 V consumers to MF outputs

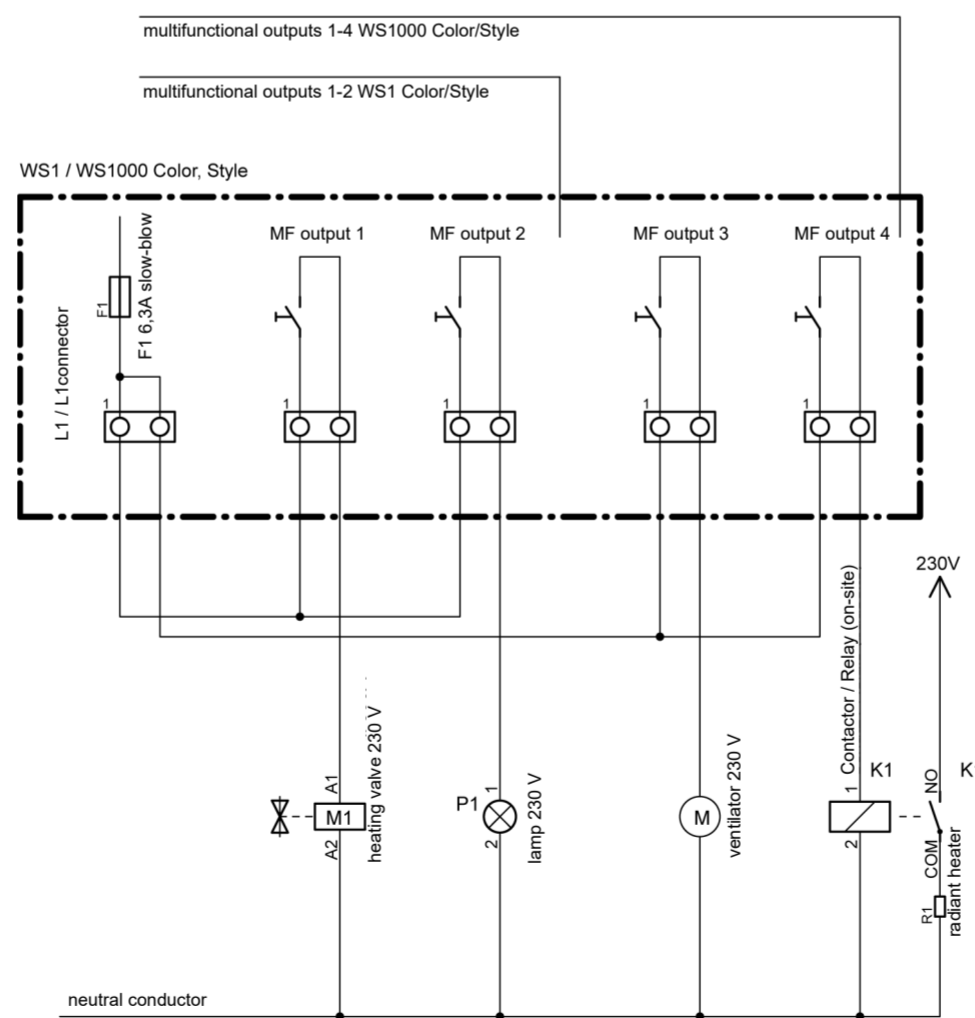

Connecting low-voltage consumers and potential-free contacts to MF outputs

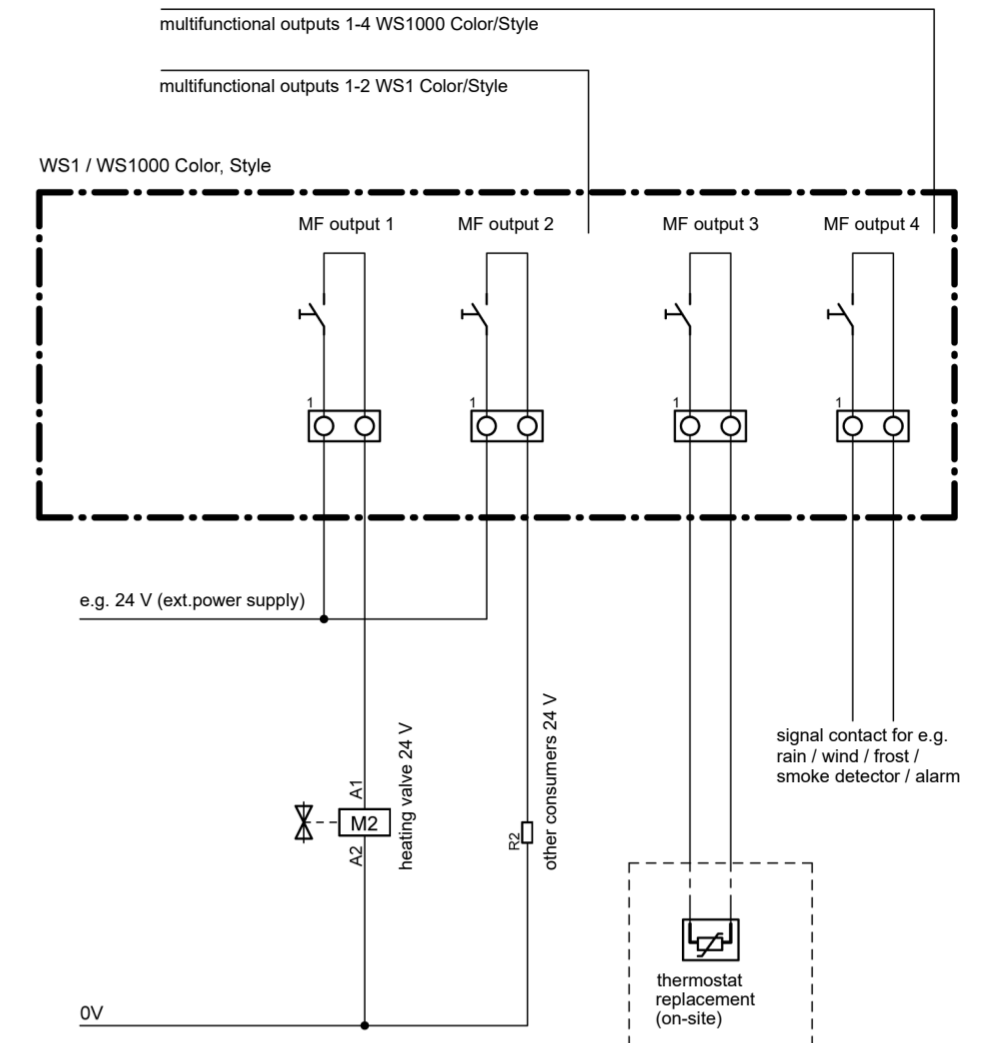

Technical specifications Control Unit WS1 Style

Housing	Glass, plastic material
Colours	• White/grey • Dark grey/black
Mounting	Flush/cavity wall
Dimensions	Display front approx. 181 x 131 (W x H, mm), mounting depth approx. 8 mm, concealed box approx. 172 x 122 x 81 (W x H x D, mm)
Ambient temperature	Operation 0...+55°C, Storage -30...+70°C
Ambient humidity	5...95% RH, avoid bedewing
Operating voltage	230 V AC, 50 Hz
Power consumption	Stand-by max. 11 W
Loading capacity drive outputs	per drive output max. 400 W, total max. 1.5 kW
Frequency wireless channels	868.2 MHz
Degree of protection	IP 20
Measurement range temperature	0...+55°C
Measurement range humidity	5...95% RH

The product conforms with the provisions of EU directives.